

Small Angle X-ray Scattering Introduction, theory and sample preparation

Ralf Stehle

Biomolekulare NMR-Spektroskopie

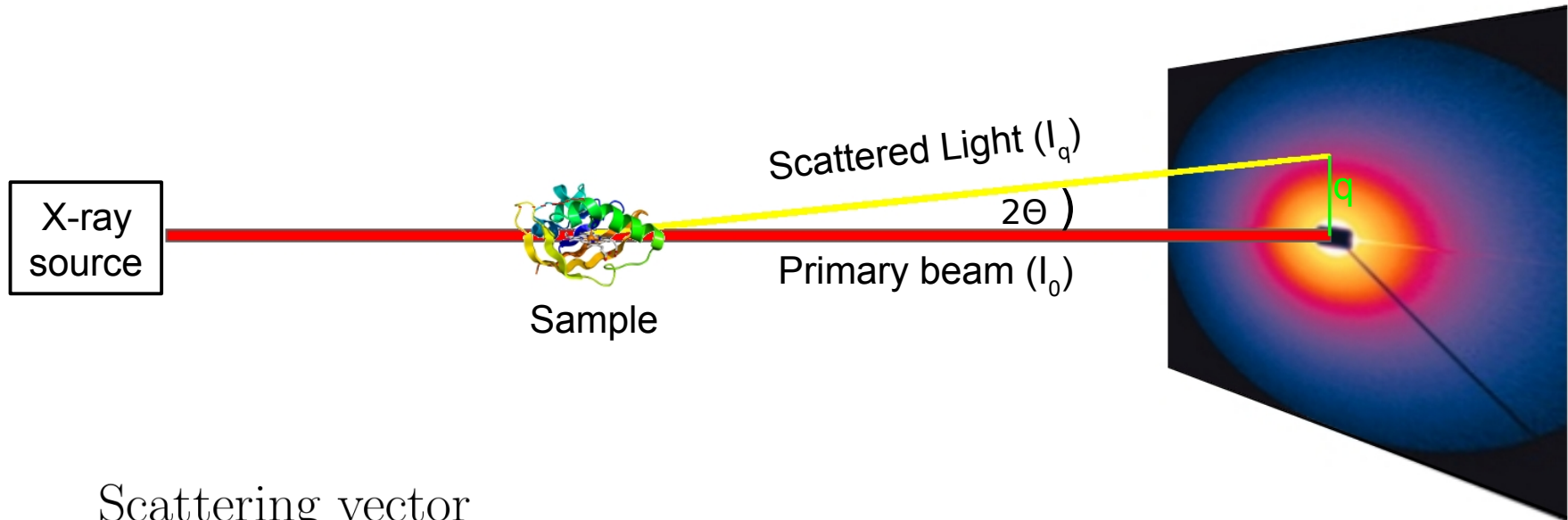

Scattering vector

$$|\vec{q}| = \frac{4\pi}{\lambda} \sin 2\theta$$

$$\vec{q} = (\vec{k}_s - \vec{k}_0) \quad k_0, k_s \text{ wave vectors of incident and scattered beam}$$

(In some publications the scattering vector is called s instead of q)

Bragg's Law

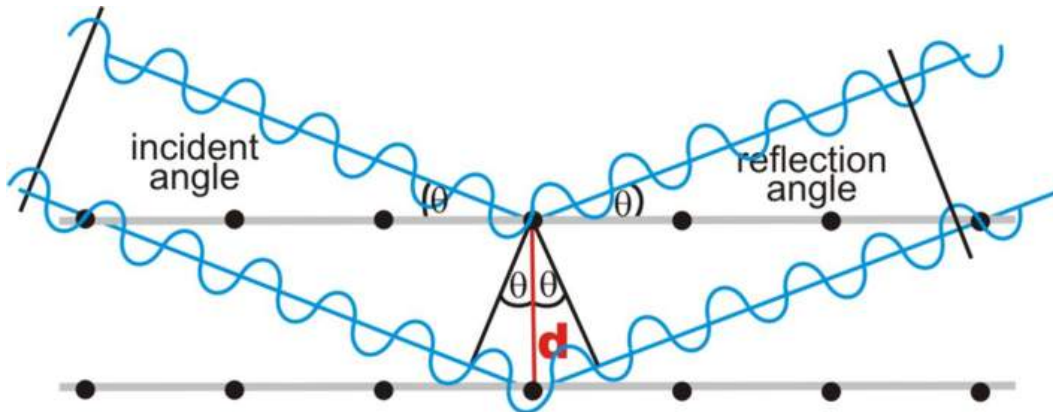

Destructive interference

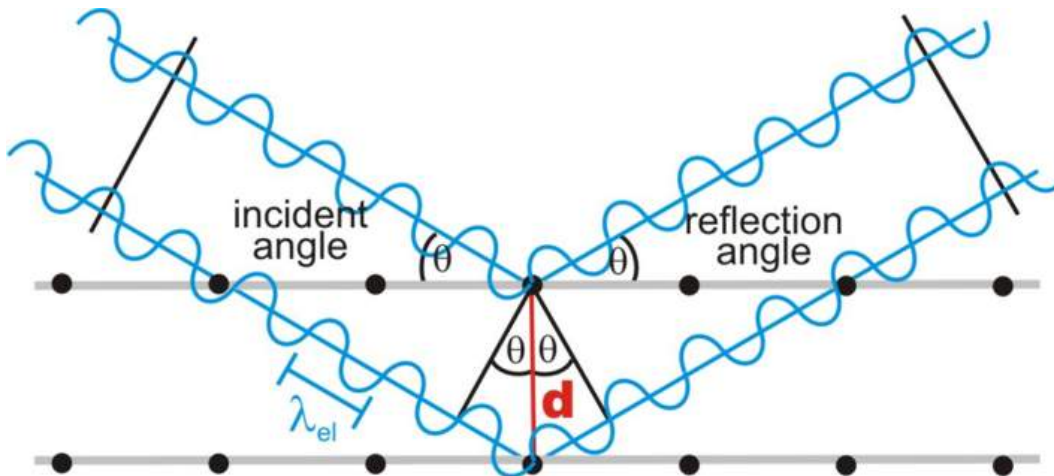

Constructive interference

Scattering vector

$$|\vec{q}| = \frac{4\pi}{\lambda} \sin 2\theta$$

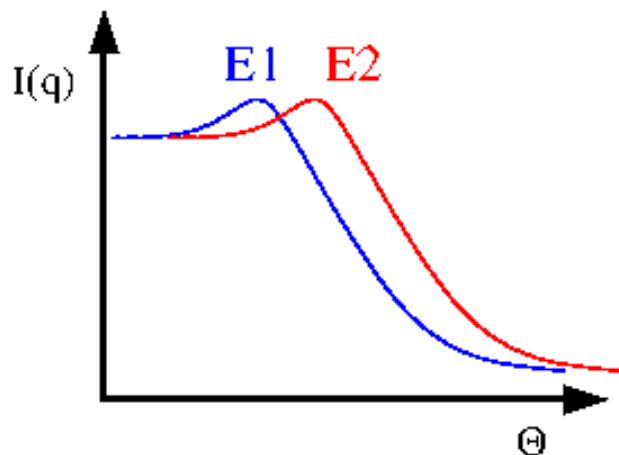

normalisation by
x-ray energy \rightarrow

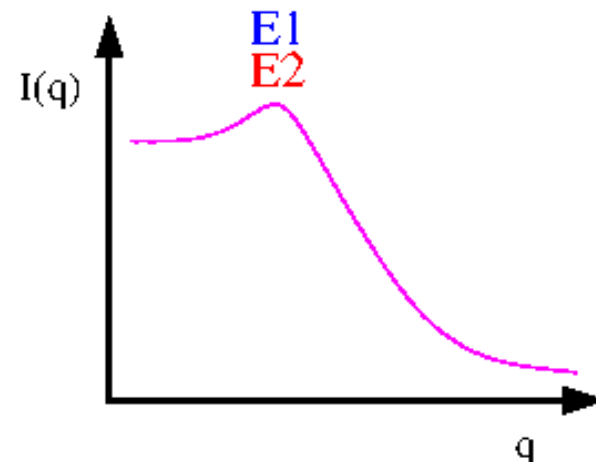

Bragg's Law

Constructive interference

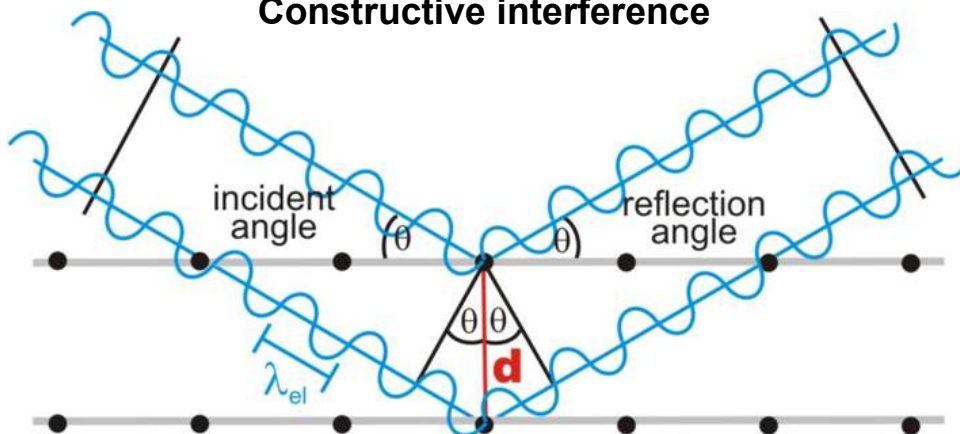

Single crystal diffraction

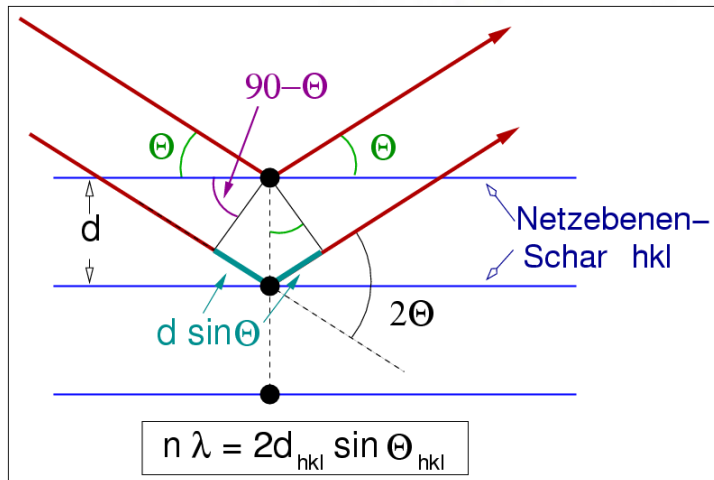
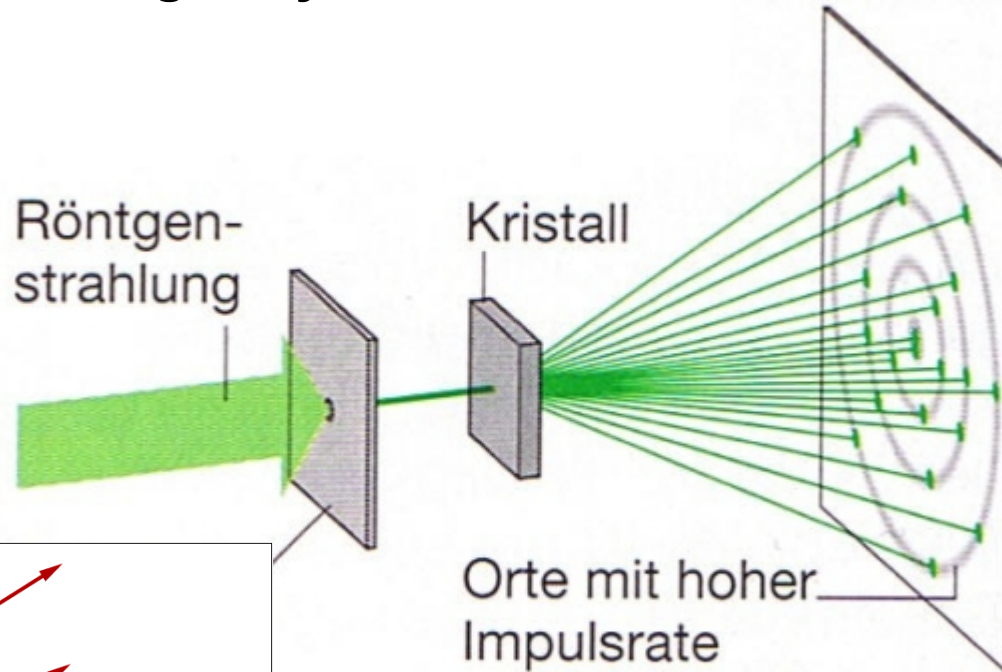

- Orientation of the crystal is known
- Scattering vector q
- orientation in reciprocal space hkl

Small angle scattering and Single crystal diffraction

Defined orientation of molecules in a crystal

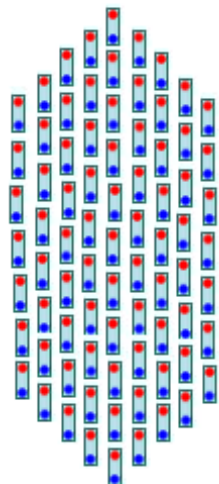

Braggs Law

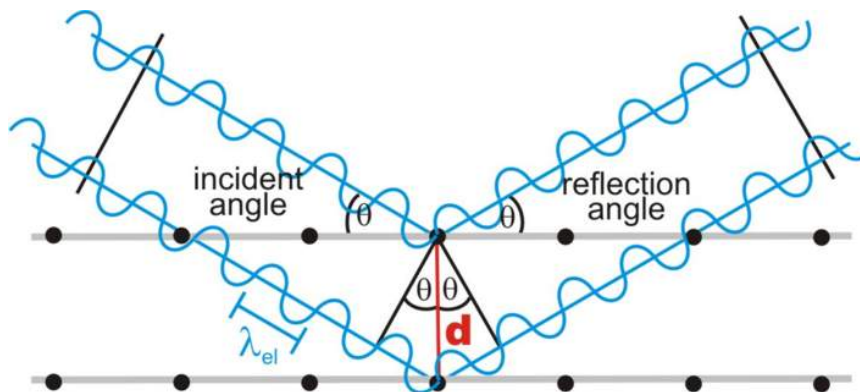

Random orientation of molecules in solution

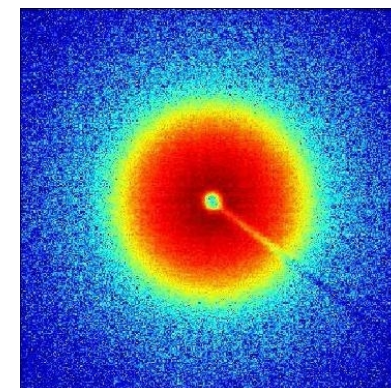
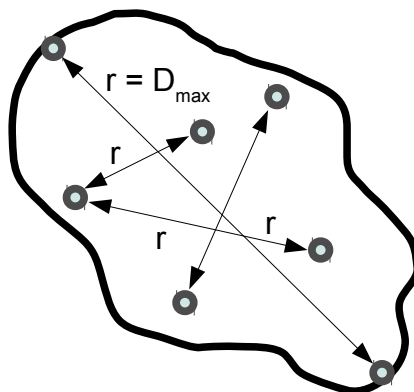
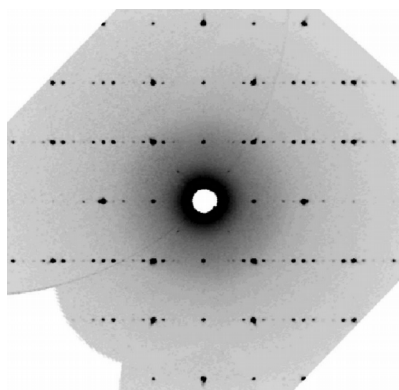
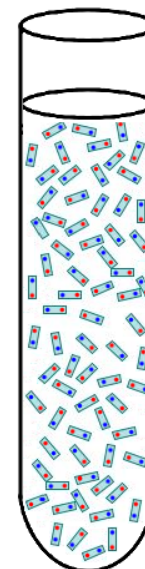

Scattering contrast

Electron density contrast

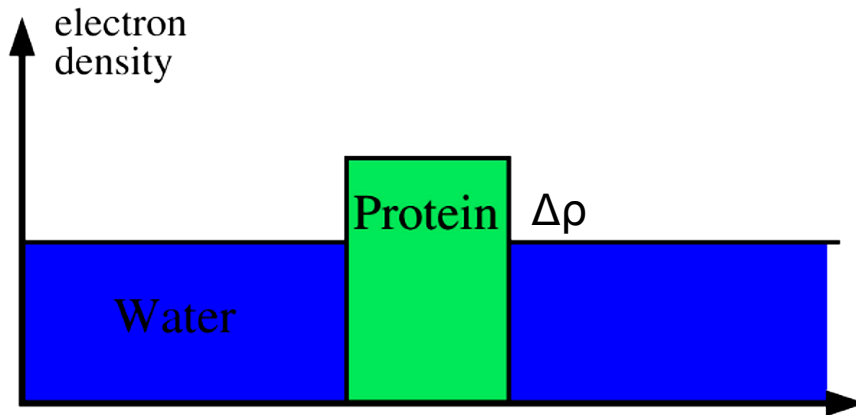

Optical contrast

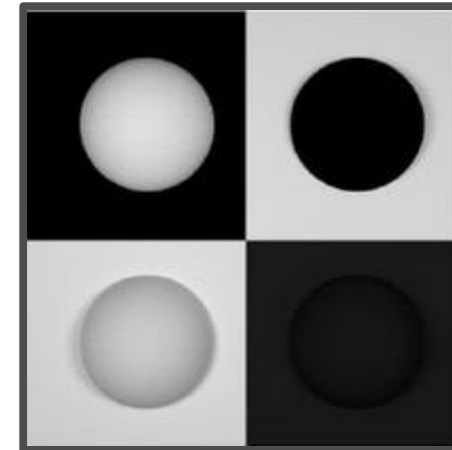

Excess electron density

$$\Delta\rho_{Ala} = \rho_{Ala} - \rho_{H_2O} V_{Ala}$$

Substance	e ⁻	Vol. [nm ³]	SLD [cm ⁻²]
H ₂ O	10	0.029	9.5 * 10 ¹⁰
Ala	48	0.104	1.3 * 10 ¹¹
Au	79	0.011	1.4 * 10 ¹²
NaCl	28	0.044	1.8 * 10 ¹¹

Scattering contrast

Electron density contrast

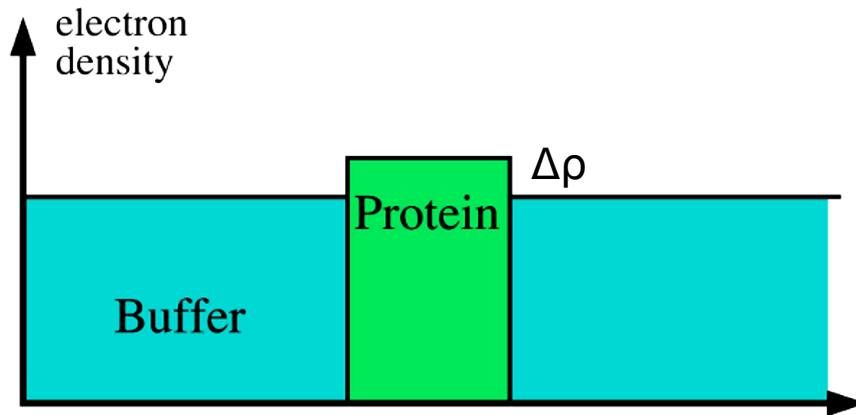

Optical contrast

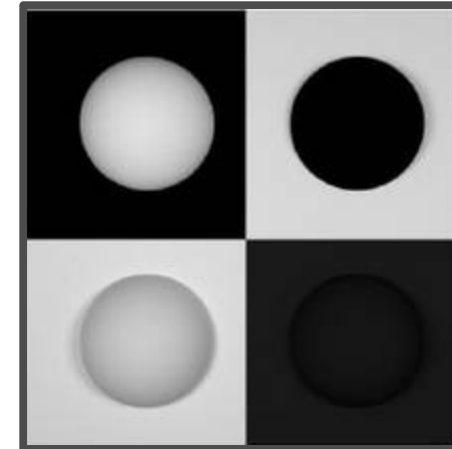

Excess electron density

$$\Delta\rho_{Ala} = \rho_{Ala} - \rho_{H_2O} V_{Ala}$$

Substance	e ⁻	Vol. [nm ³]	SLD [cm ⁻²]
H ₂ O	10	0.029	9.5 * 10 ¹⁰
Ala	48	0.104	1.3 * 10 ¹¹
Au	79	0.011	1.4 * 10 ¹²
NaCl	28	0.044	1.8 * 10 ¹¹

Two Phase problem and contrast

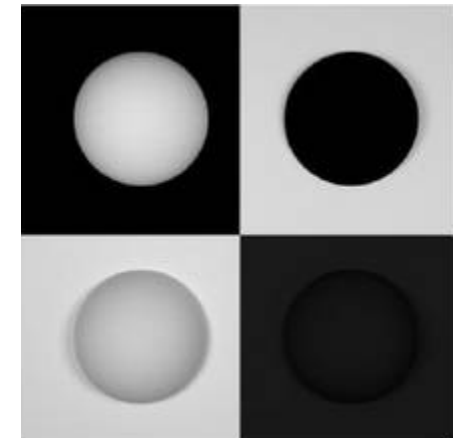

Fig. 1. (a) "White" holes in "black" matrix; (b) "Black" grains in a "white" solvent.

$$A(q) = \int_{\Phi V} \rho_1 e^{-iq \cdot r} dr + \int_{(1-\Phi)V} \rho_2 e^{-iq \cdot r} dr \quad \Phi = \text{Volume Fraction}$$

$$A(q) = \int_{\Phi V} (\rho_1 - \rho_2) e^{-iq \cdot r} dr + \rho_2 \int_V e^{-iq \cdot r} dr$$

$$A(q) = \int_{\Phi V} \Delta \rho_1 e^{-iq \cdot r} dr + \rho_2 \delta(q)$$



- $\Delta \rho$ is equal to $(\rho_1 - \rho_2)$ in Φ and zero elsewhere
- For $(q \neq 0)$ The scattered intensity depends only on the contrast between both phases

Scattering Intensity

Scattering Vector

$$q = (4 \pi / \lambda) \sin(2 \theta) = (\vec{k}_s - \vec{k}_i)$$

k_i, k_s wave vectors of incident and scattered beam

$$I(q) = \frac{A(q) A^*(q)}{V} \quad \text{Scattering Intensity}$$

$$I(q) = \frac{1}{V} \int_V \int_V \rho(r) \rho(r') e^{-iq \cdot (r - r')} dr dr'$$

Correlation function $\gamma(r) = \frac{1}{V} \int_V \rho(r') \rho(r + r') dr' = \frac{1}{V} P(r)$ Patterson Function

$$I(q) = \int_V \gamma(r) e^{-iq \cdot r} dr$$

Form Factor

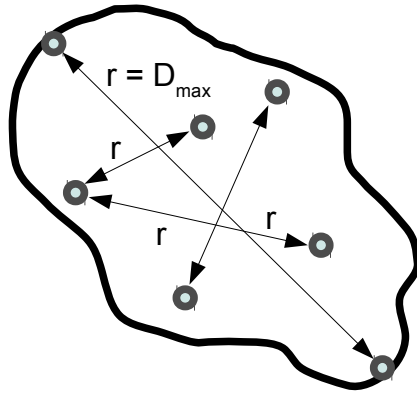

$$a(q) = \int_{V_{Part}} \rho(r) e^{-iq \cdot r} dr$$

Amplitude

$$I_{Part} = a(q) a^*(q) = V_{Part}^2 P(q)$$

Intensity

$$P(q) = \frac{1}{V_{Part}^2} \int \int \rho(u) \rho(v) e^{-iq \cdot (u-v)} du dv$$

Form Factor

$$I_a(q) = \frac{N}{V} V_{Part}^2 P(q) = \Phi V_{Part} P(q)$$

Intensity per unit volume

N = Number of particles

Structure Factor and Form Factor

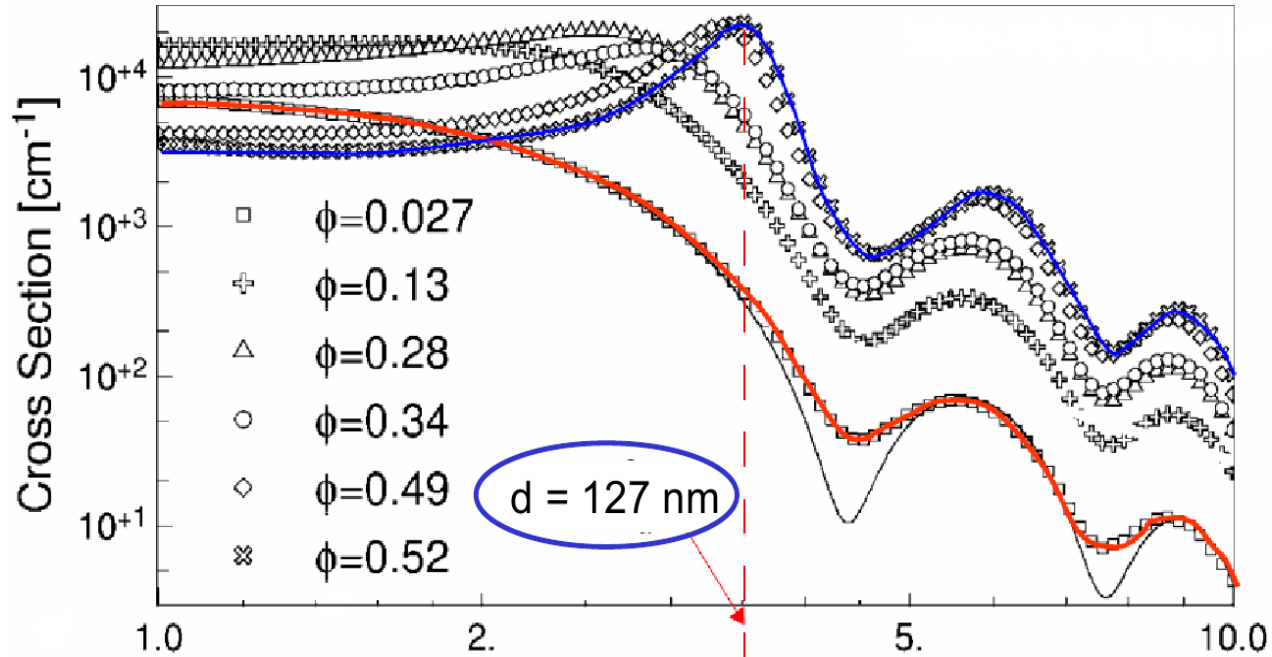

PS nano particles R=66.5 nm. Φ =volume fraction.

structure factor

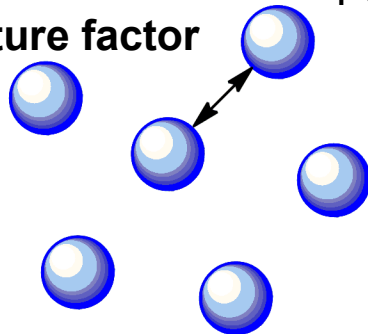

$$I_a(q) = \Phi V_{Part} P(q) S(q)$$

form factor

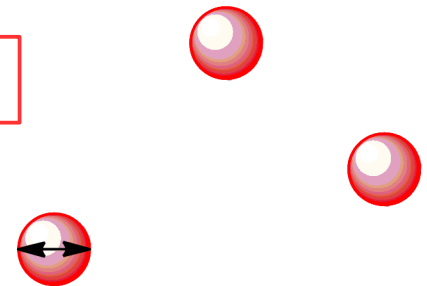

icles

Form Factor Averaged over all Orientations

$$P(q) = \frac{1}{V_{Part}} \int_{V_{Part}} \gamma(r) e^{-iq \cdot r} dr$$

Form factor with auto correlation function

Averaging over solid angle

$$\gamma_{Part}(r) = \langle \gamma_{Part}(r) \rangle_{\Omega} \quad P(q) = \langle P(q) \rangle_{\Omega} \quad \Omega = \text{solid angle}$$

$$P(q) = \frac{1}{V_{Part}} \int_{V_{Part}} \left(\frac{1}{4\pi} \int_{\Omega} \gamma(r) d\Omega \right) e^{-iq \cdot r} dr$$

$$P(q) = \frac{1}{V_{Part}} \int_0^D 4\pi r^2 \gamma_{Part}(r) \frac{\sin(qr)}{qr} dr$$

$$D = D_{max}$$

Scattering intensity Averaged over time and Absolute Calibration

Local scattering length
density fluctuations

$$\eta(r) = \rho(r) - \langle \rho \rangle$$

$\langle \rho \rangle =$ Density fluctuations
averaged over time

Normalised correlation function

$$\gamma_0(r) = \frac{\gamma(r) - \langle \rho \rangle^2}{\langle \eta^2 \rangle}$$

$$I(q) = \langle \eta^2 \rangle \int_V \gamma_0(r) e^{-iq \cdot r} dr$$

SAXS Absolut Calibration

$$\sigma = \frac{\text{Scattered energy}}{\text{Incident energy per unit area}}.$$

Scattering cross section

$$\frac{d\Sigma}{d\Omega} = n \frac{d\sigma}{d\Omega}.$$

Macroscopic Scattering cross section

$$\frac{d\Sigma(q)}{d\Omega} = c \rho^2 \bar{v}^2 M_1 P(q).$$

Molecular Weight

ρ Scattering contrast
 \bar{v} Specific volume
 $P(q)$ Form factor

Absolut Scattering of water

$$\frac{d\Sigma}{d\Omega} = \rho^2 kT \chi_T,$$

χ = Isothermal compressibility
 ρ = Scattering length density

Absolut calibration of Sample

$$\left(\frac{\partial\Sigma}{\partial\Omega}\right)_S(q) = \left(\frac{\partial\Sigma}{\partial\Omega}\right)_{st}(q) \frac{[I_S(q) - BG_S]}{d_S T_{S+CAP}} \frac{d_{st} T_{st+CAP}}{[I_{st}(q) - BG_{st}]}$$

d = Thickness
 T = Transmission
 BG = Background

X-Rays, instrumental setup and measurement

X-Ray production

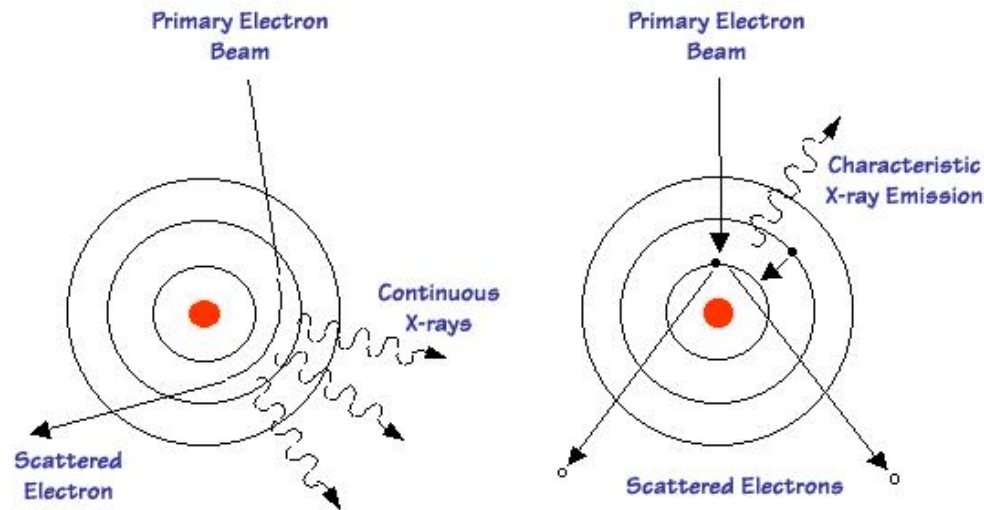

www2.rgu.ac.uk/life_semweb/xrayfig1.gif

Accelerated electrons hit atoms inside of the anode.

- The electron can be scattered by the atom loses energy which is emitted as irradiation (Bremsstrahlung)
- The fast electron kicks an electron out of the K-shell. A third electron is falling from the L or M shell into the K shell. The energy difference is emitted as x-ray irradiation ($K_{\alpha/\beta}$ irradiation)

Energy spectrum of a Cu Laboratory source

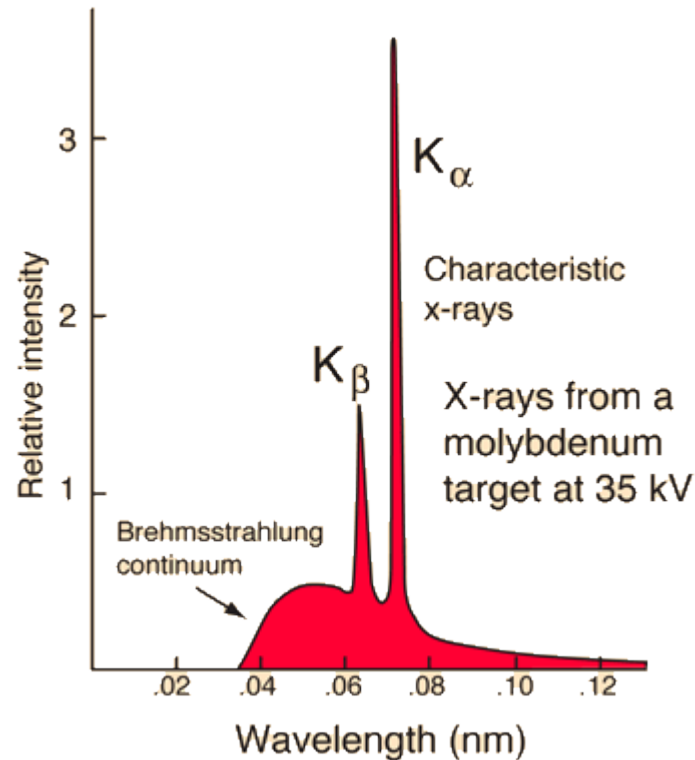

K_{α} irradiation is emitted from an L - K transition

K_{β} irradiation is emitted from an M - K transition

Sealed Tube

Acceleration of electrons of high voltage Inside an evacuated tube between filament and Anode

Target: Cu, Mo, W (anode)
40 – 60 kV, 10 – 30 mA
 10^6 Photons/s

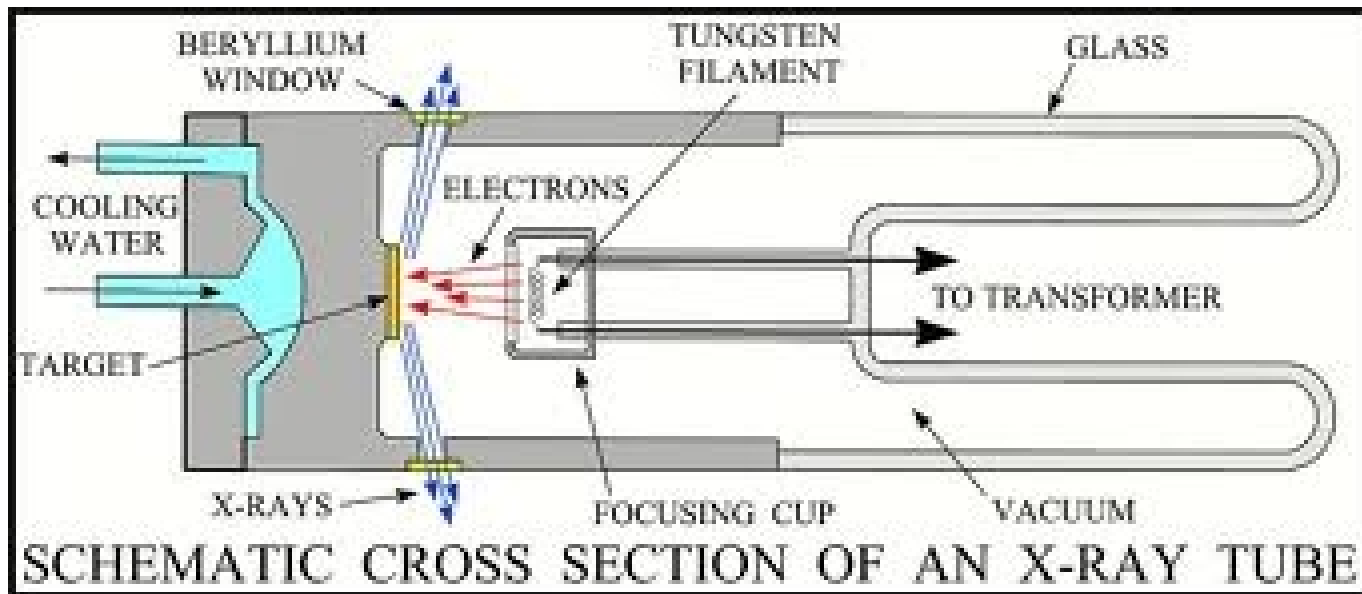

Simple design very stable but relatively low amount of photons

Sealed

Acceleration of electrons of high voltage
between filament and Anode

Target: Cu, Mo, W (anode)
40 – 60 kV, 10 – 30 mA
 10^6 Photons/s

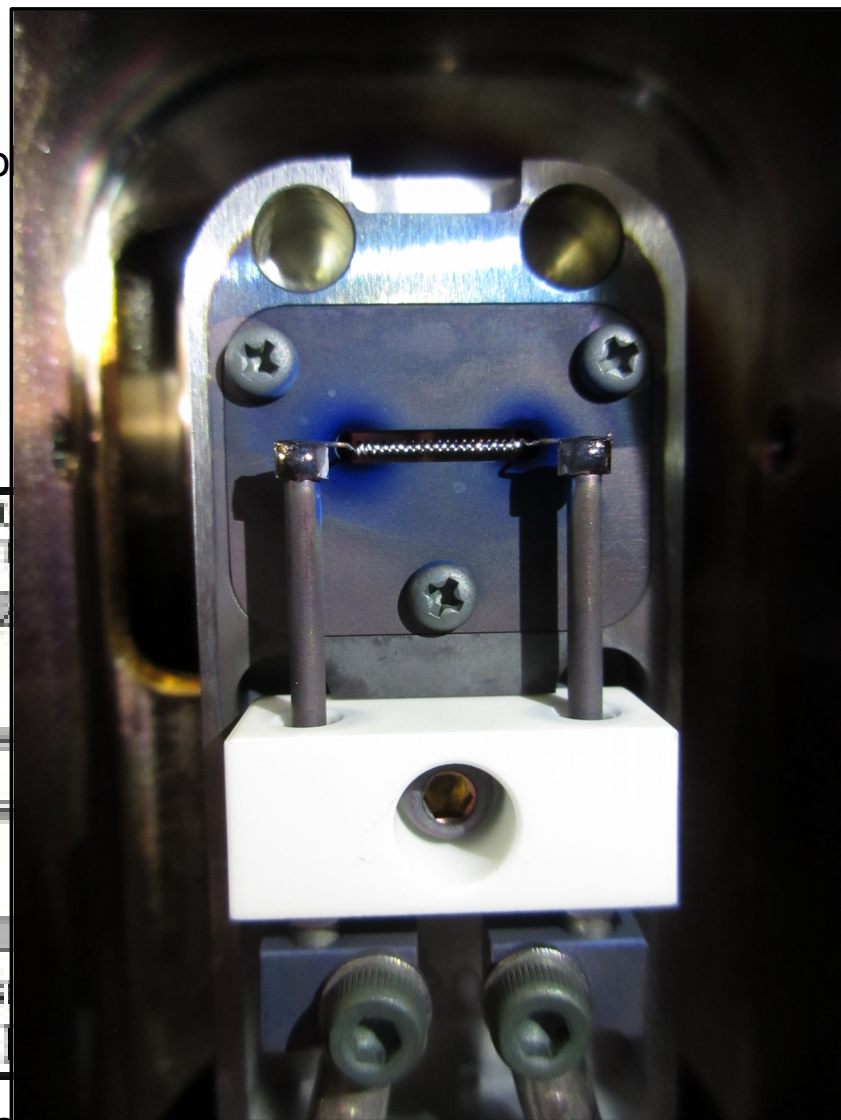
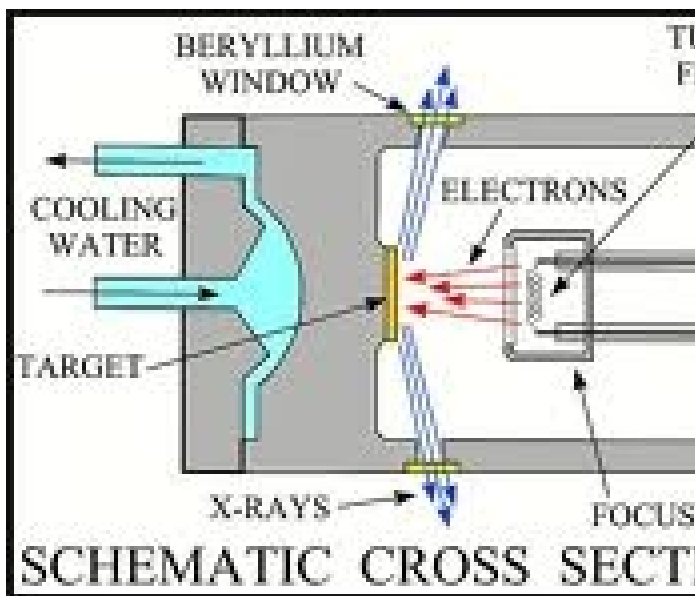

Simple design very stable but relatively low amount of photons

Rotating Anode

Target: Cu, Mo, W (anode)
40 – 60 kV, up to 200 mA
 10^8 Photons/s

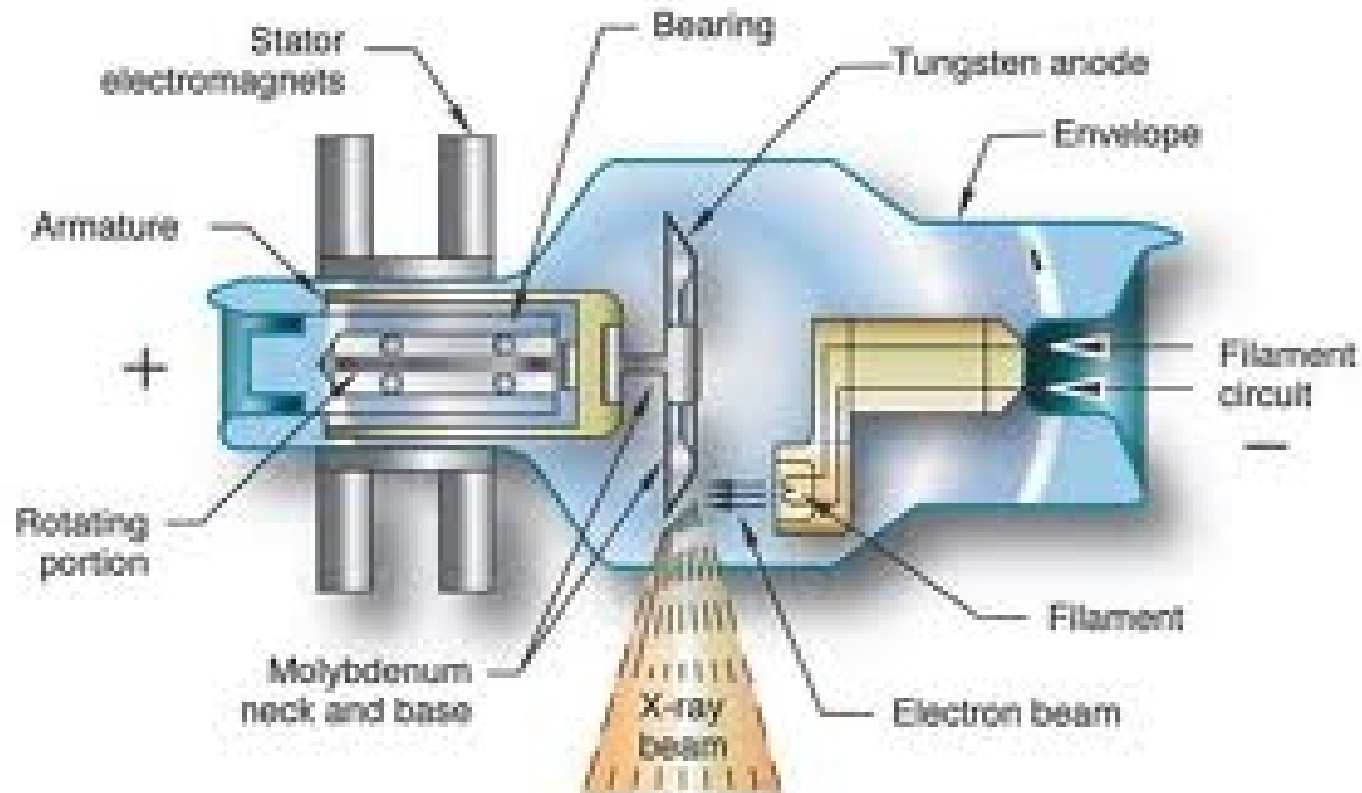

high amount of photons, due to moving parts high maintenance time and effort

Rotating Anode

Target: Cu, Mo, W (anode)

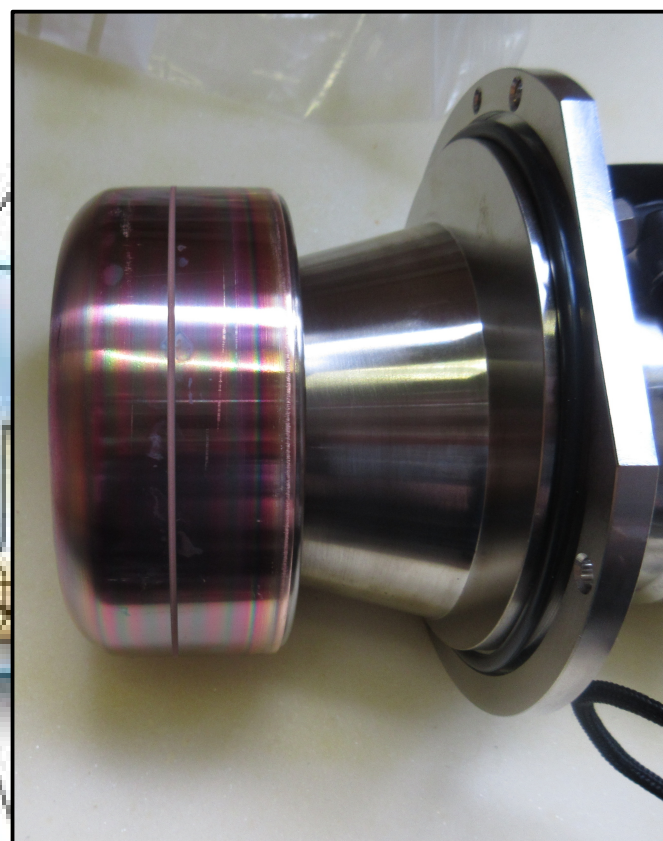
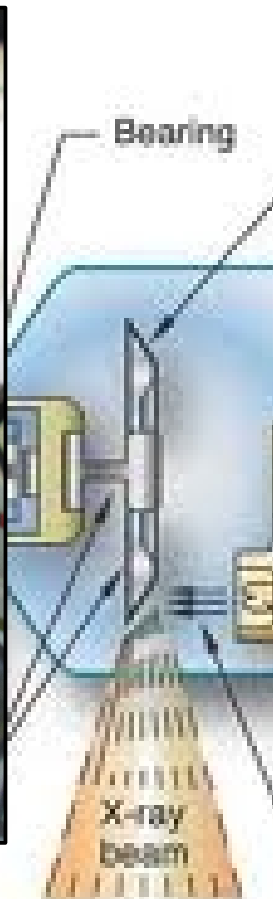
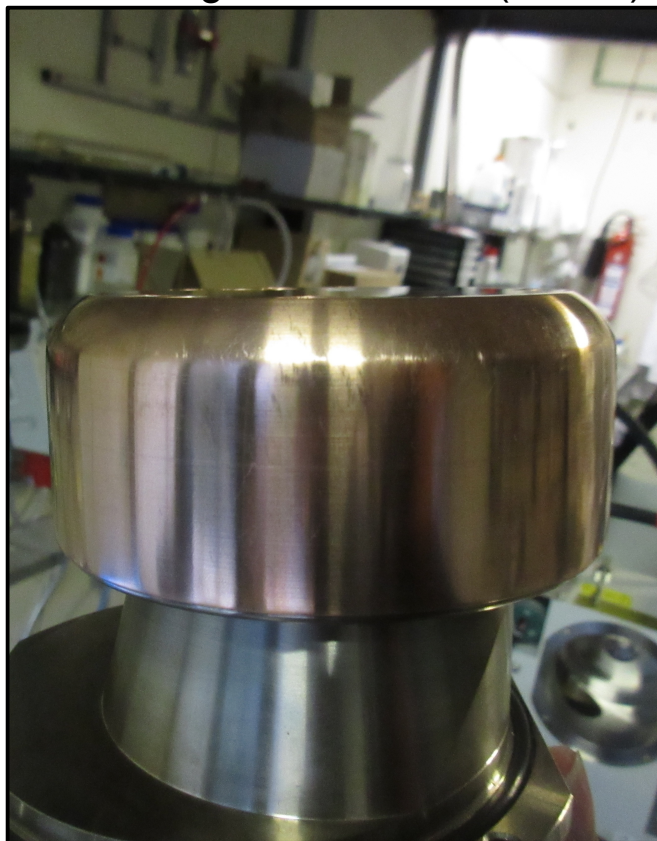

high amount of photons, due to moving parts high maintenance time and effort

Synchrotron

Evacuated ring tube

4.5 - 6 GeV, 20 - 300 mA single or multi bunch

Up to 10^{14} Photons/s

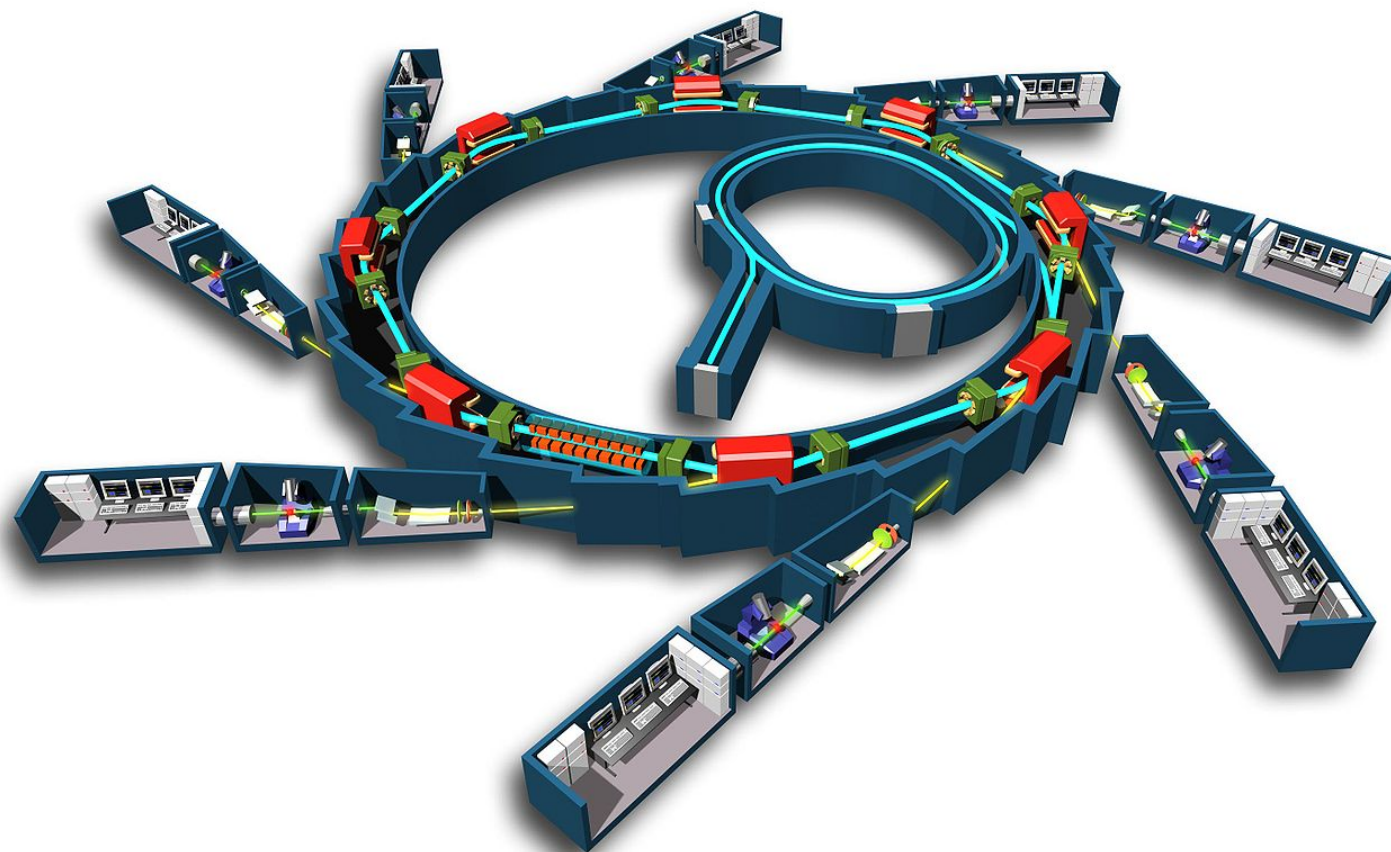

Undulator/Wiggler at a synchrotron

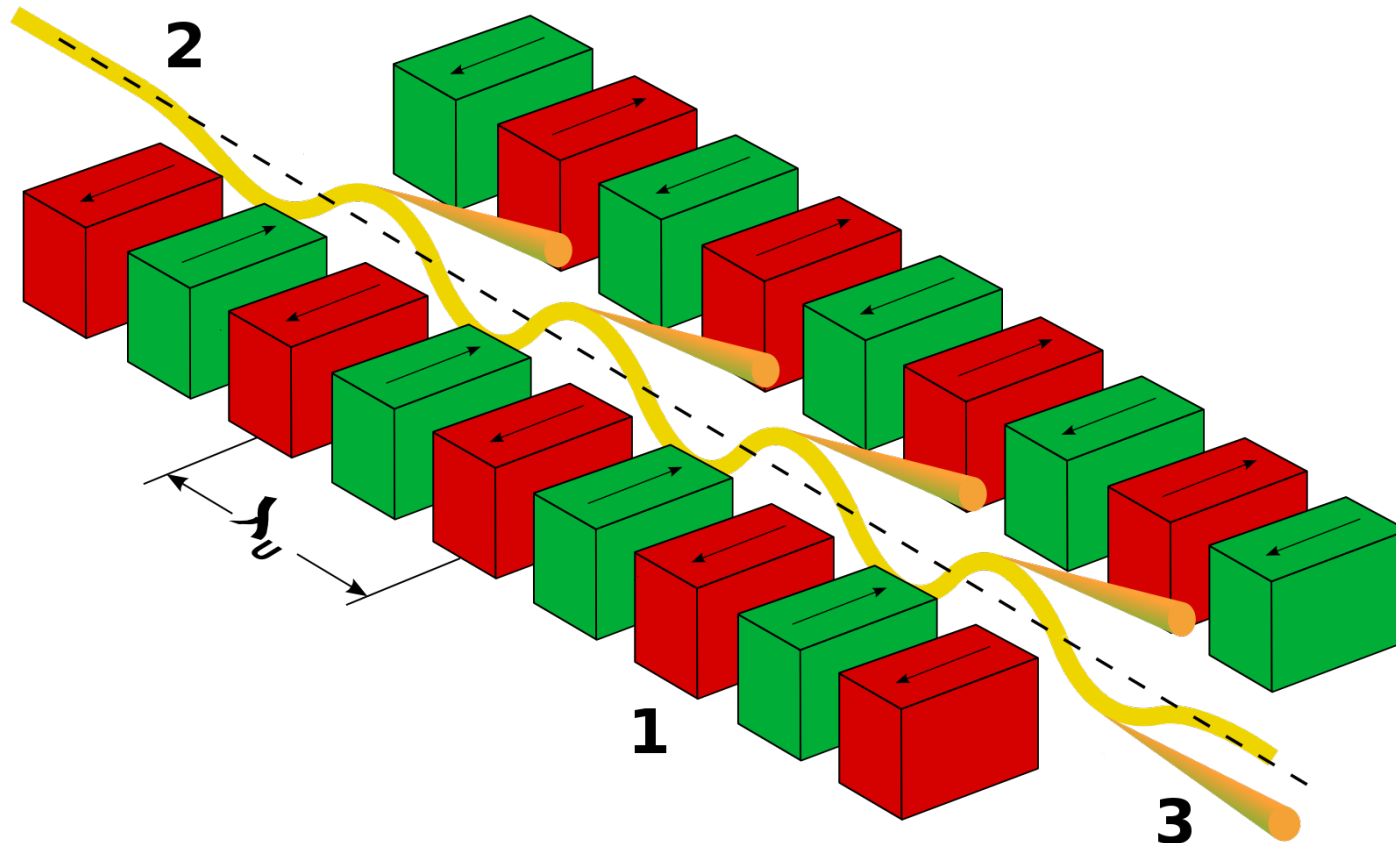

Alternating angular acceleration of the electron beam leads to a tangential emission of irradiation. The overlaying beams from top and bottom are used for experiments.

Energy spectrum at synchrotrons

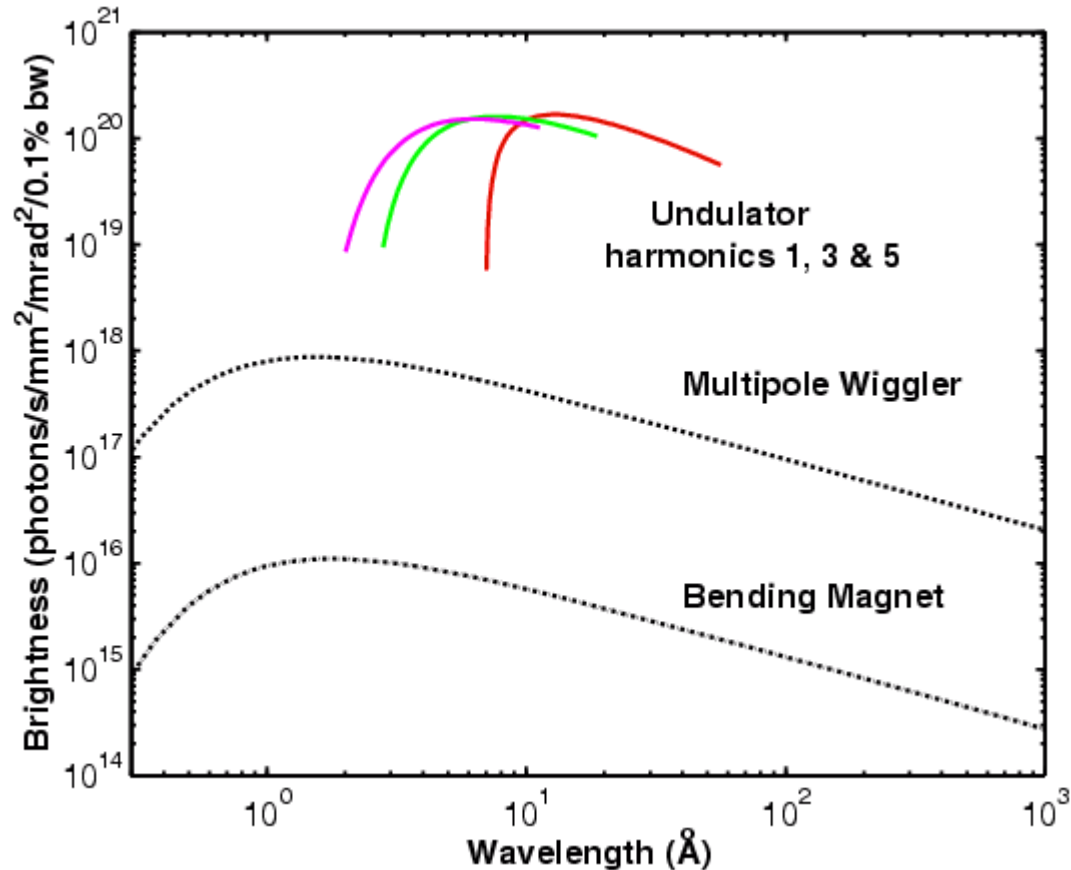

- Bending magnets have a low intensity but a wide energy range.
- Wigglers have a spectrum like a bending magnet with much more intensity.
- With Undulators a much higher energy is possible however the energy range is very limited.

B1 beamline at Doris III Hasylab Hamburg

Dedicated ASAXS Beamline
5- 35 keV, 10^6 photons/s

← X-ray direction

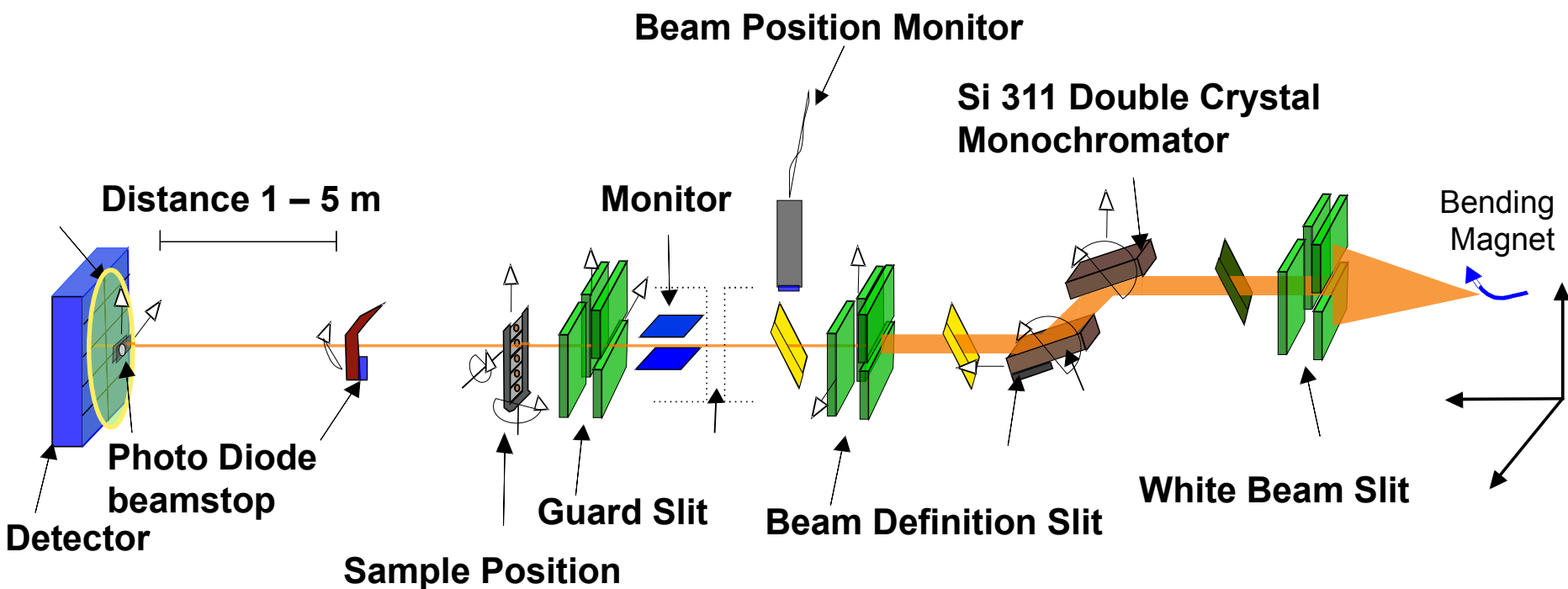

X-ray optics

Due to weak interaction of x-rays with matter there are no normal lenses for x-rays.

- To get a fine beam the primary beam is normally cut by slits.
- Plane mirrors are used under total reflection conditions.
- Multilayered planar mirrors are used for monochromatisation.
- Since 1995 parabolic or ellipsoid mirrors are available to focus x-rays (Göbel mirrors).

For SAXS experiments those mirrors have to be very smooth.

Contrary to single crystal diffraction in SAXS experiments the beam is focused at the detector and not at the sample position.

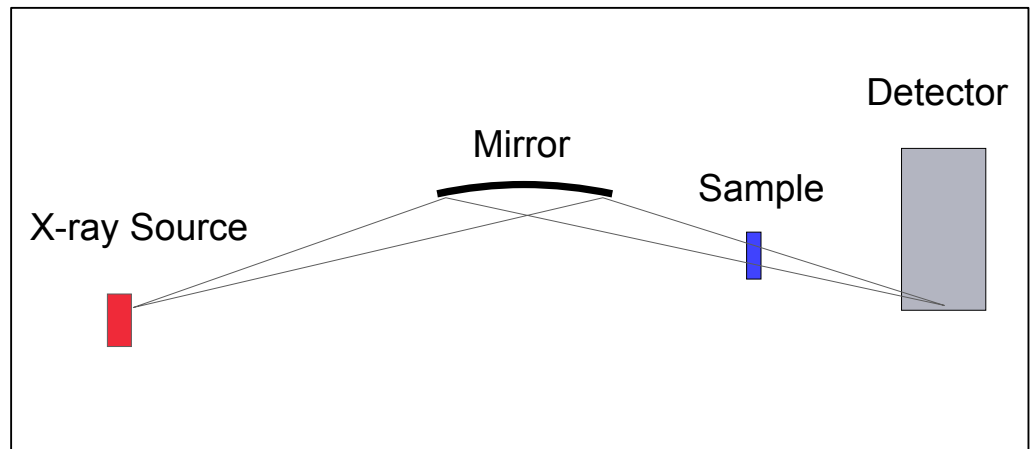
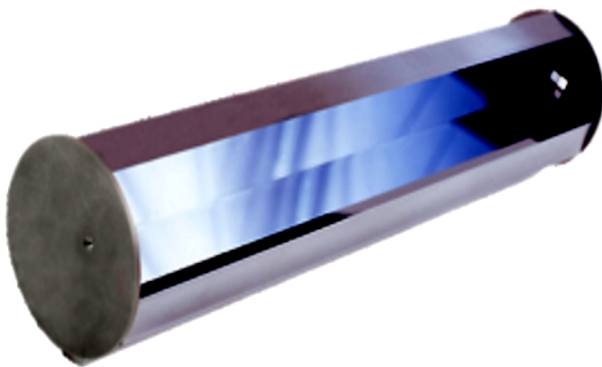

Laboratory Instruments Kratky Camera

X-ray source

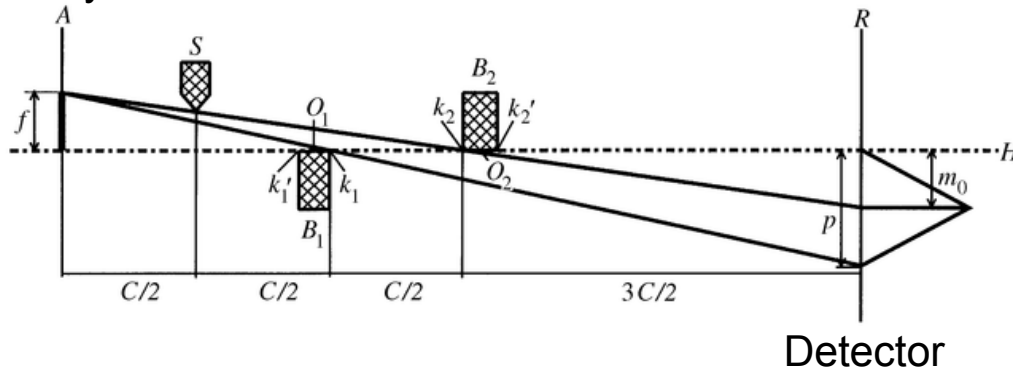

Side view of the collimation system of a Kratky camera. The beam is cut to its size by the metal blocks B1 and B2. To avoid reflections on the metal surface both surfaces have to be on the same plane (H).

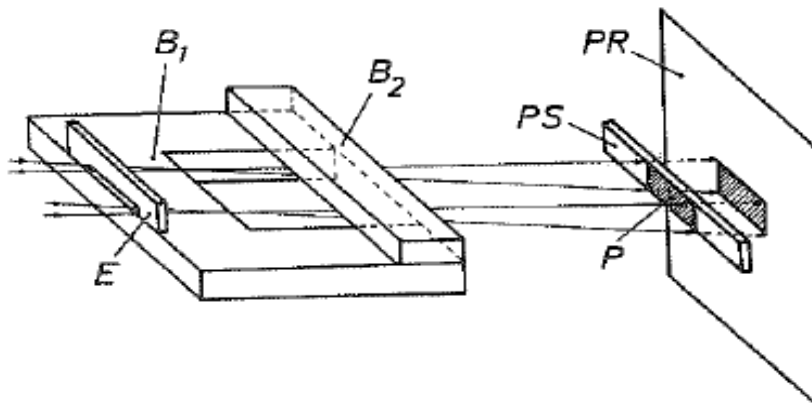

Side top view of the collimation system. To increase the resulting scattering intensity the sample (PS) is illuminated with a bar shaped beam.

Kratky Camera smeared beam profile

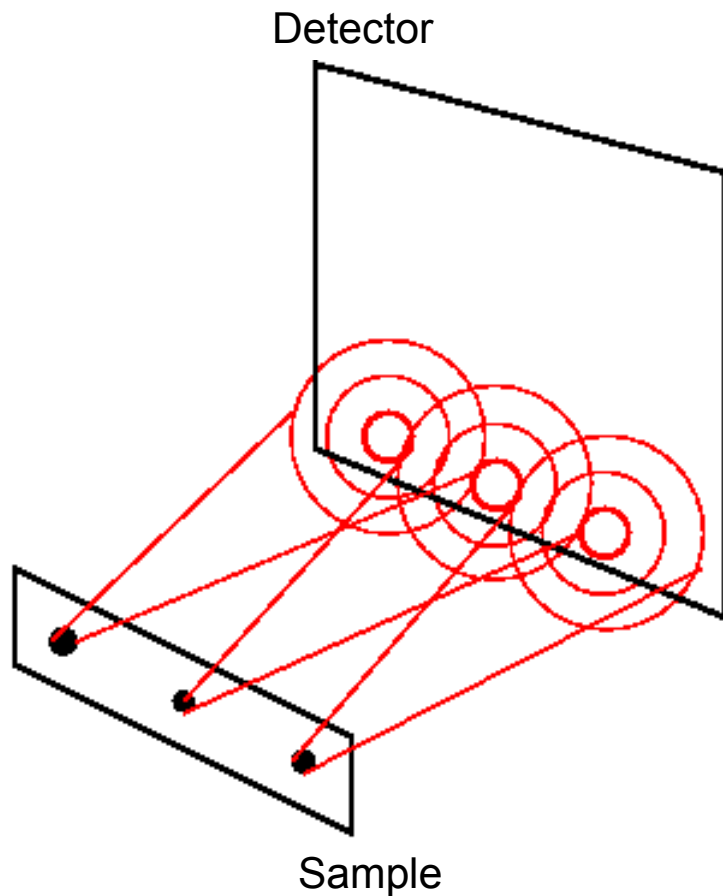

Due to slit collimation the scattering pattern gets smeared. Scattering of different beam centers is overlaying each other.

Empty beam profile of a Kratky camera. Sigmoidal fit to the data to get the trapezoidal primary beam profile. With this beam profile the desmearing has to be done iteratively.

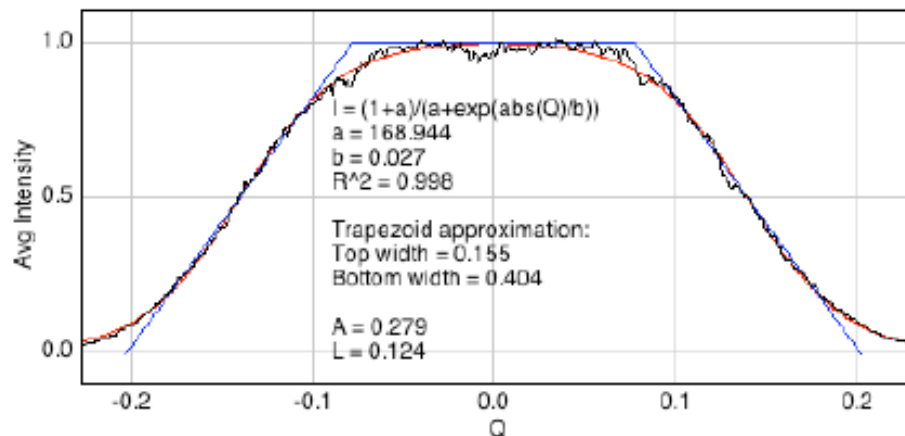

SAXS measurement

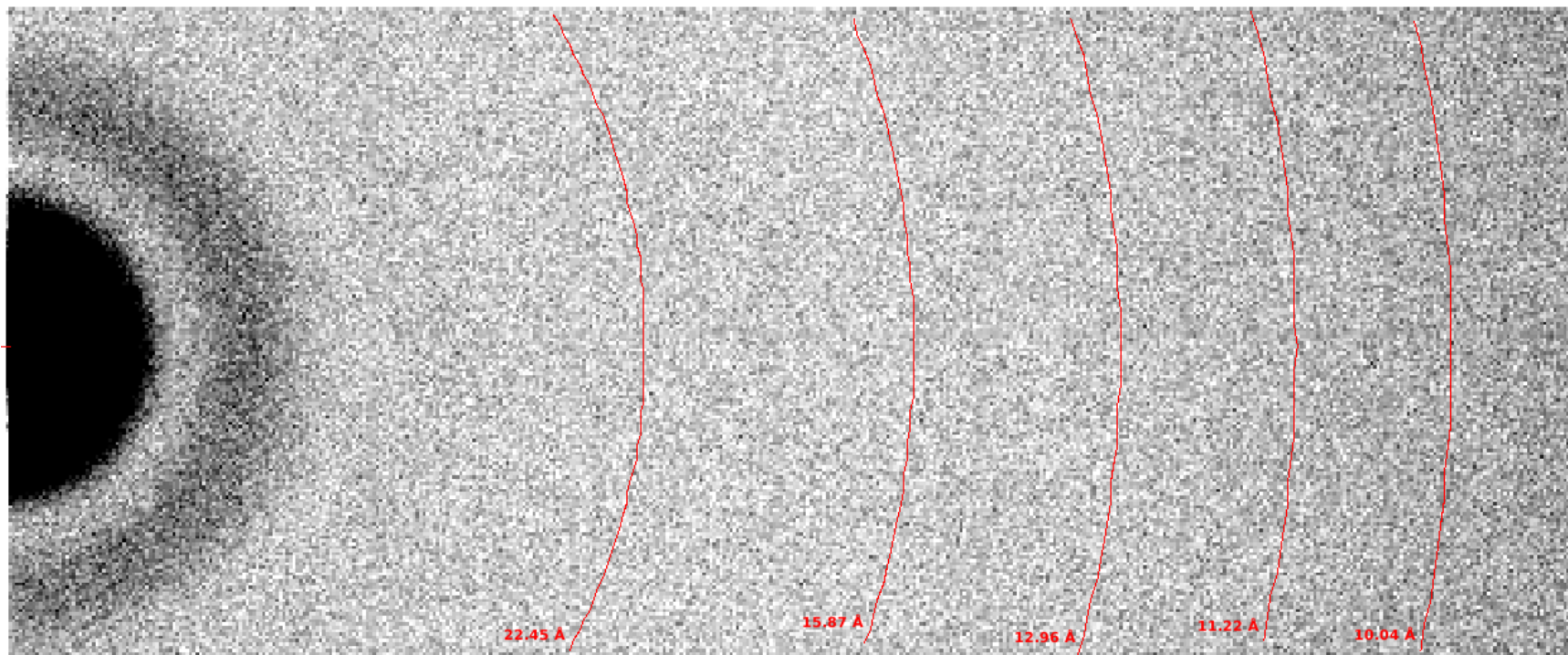

hclpp 5 mg/ml 1 hour average of 4 frames

q-calibration and beam center

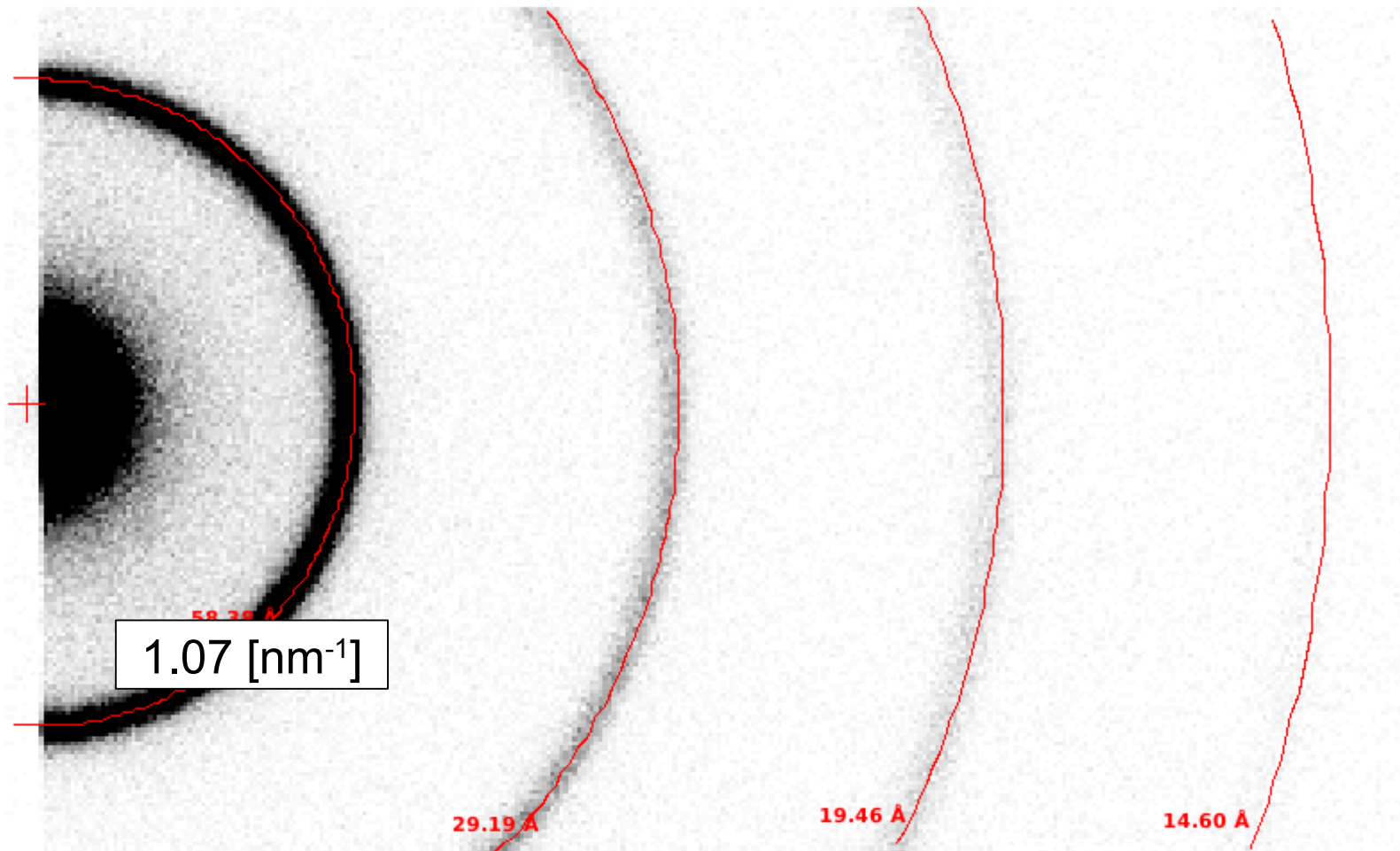

Ag Behenate 30 s beam center: 482.7x90.9 [px], detector dist 482,1 [mm]
pixel size 79 [μm]

Raw scattering curves

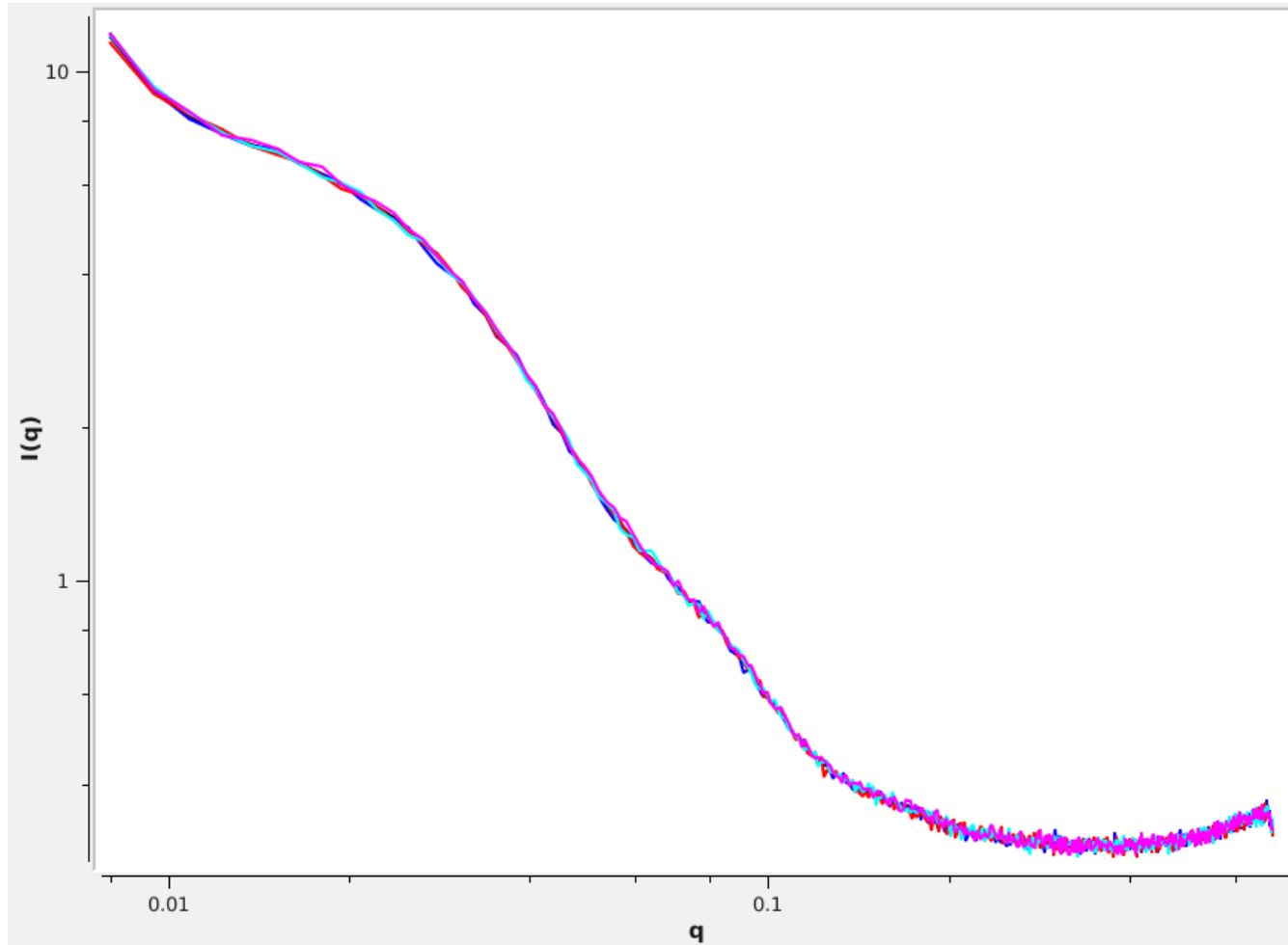

IgG 5 mg/ml 4 frames of 900 s each and the average. They have to fall upon each other.

Raw scattering curves

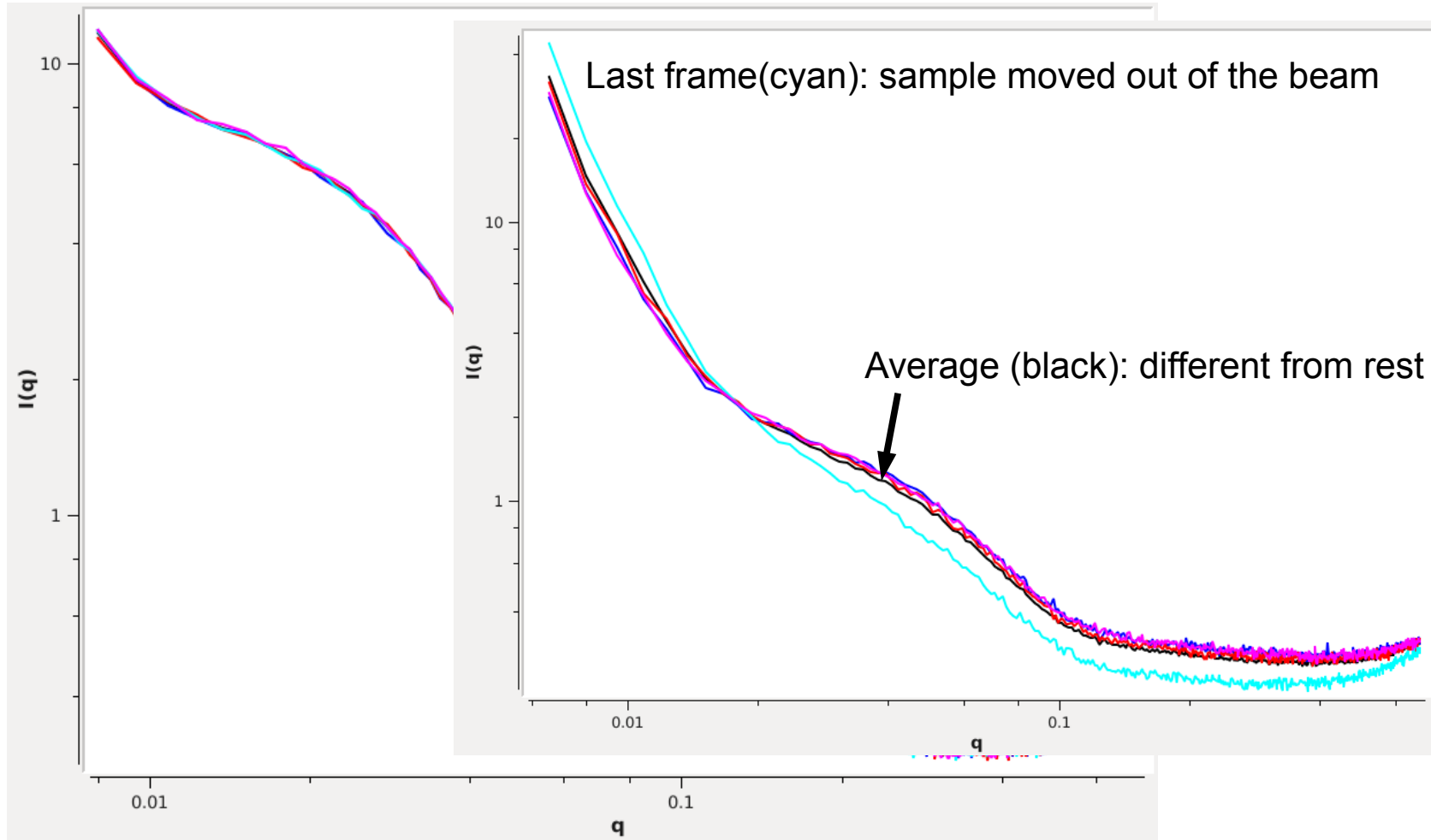

IgG 5 mg/ml 4 frames of 900 s each and the average. They have to fall upon each other.

Raw scattering curves from IgG and solvent

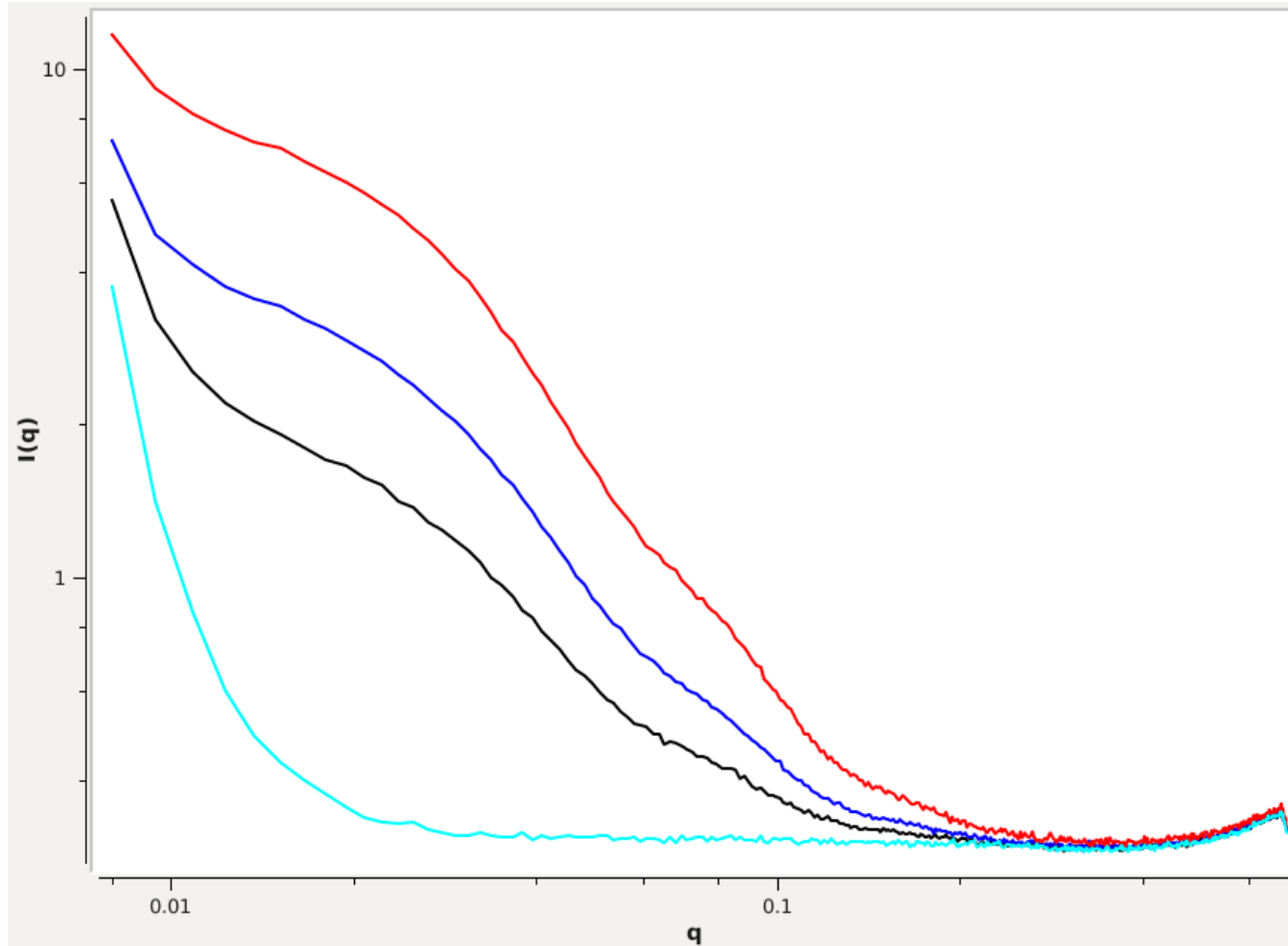

IgG red 5 mg/ml blue; 2.5 mg/ml; black 1.25 mg/ml; Buffer cyan (5mg 1h, rest 2 h)

Solvent subtraction

Experimental Data

$$I_{Sample} = (I_{Protein} + I_{Water} + I_{Salt} + I_{Capillary} + I_{Background})$$

$$I_{Solvent} = (I_{Water} + I_{Salt} + I_{Capillary} + I_{Background})$$

Transmission

$$Tr = \frac{I_s}{I_0}$$

I_s Sample Intensity

I_0 Empty Beam Intensity

(both measured with a photo diode behind the sample position)

Typical transmissions for SAXS experiments are between 0.2 - 0.3

Solvent subtraction simple case $Tr_{Sample} \approx Tr_{Solvent}$

$$I_{Protein} = \frac{I_{Sample}}{Tr_{Sample} * d} - \frac{I_{Solvent}}{Tr_{Solvent} * d} \quad Tr_{Sample} \approx Tr_{Solvent} \quad d \text{ capillary thickness}$$

Solvent subtraction

Experimental Data

$$I_{Sample} = (I_{Protein} + I_{Water} + I_{Salt} + I_{Capillary} + I_{Background})$$

$$I_{Solvent} = (I_{Water} + I_{Salt} + I_{Capillary} + I_{Background})$$

$$I_{Capillary} = (I_{Empty Capillary} + I_{Background})$$

$$I_{Background} = (I_{Empty beam})$$

Transmission $Tr = \frac{I_s}{I_0}$ I_s Sample Intensity
 I_0 Empty Beam Intensity
 (both measured with a photo diode behind the sample position)

Data treatment with different transmission or thickness $Tr_{Sample} \neq Tr_{Solvent}$

$$I_S = \left(\frac{(I_{Sample} - I_{Background})}{Tr_{SamplewithoutTc} * d} - \frac{(I_{Capillary} - I_{Background})}{Tr_{Capillary} * d} \right)$$

$$I_L = \left(\frac{(I_{Solvent} - I_{Background})}{Tr_{SolventwithoutTc} * d} - \frac{(I_{Capillary} - I_{Background})}{Tr_{Capillary} * d} \right)$$

$$Tr_{SamplewithoutTc} = \frac{Tr_{Sample}}{Tr_{Capillary}}$$

d capillary thickness

$$I_{Protein} = I_S - I_L$$

Solvent subtraction

$$I_{Sample} = (I_{Protein} + I_{Water} + I_{Capillary})$$

$$I_{Solvent} = (I_{Water} + I_{Capillary})$$

$$I_{Capillary} = (I_{Empty})$$

Transmission $Tr = \frac{I_s}{I_0}$

Data treatment with different t

$$I_S = \left(\frac{I_{Sample} - I_{Background}}{Tr_{SamplewithoutTc}} * \right)$$

$$I_L = \left(\frac{I_{Solvent} - I_{Background}}{Tr_{SolventwithoutTc}} * \right)$$

$I_{Protein} = I_S - I_L$

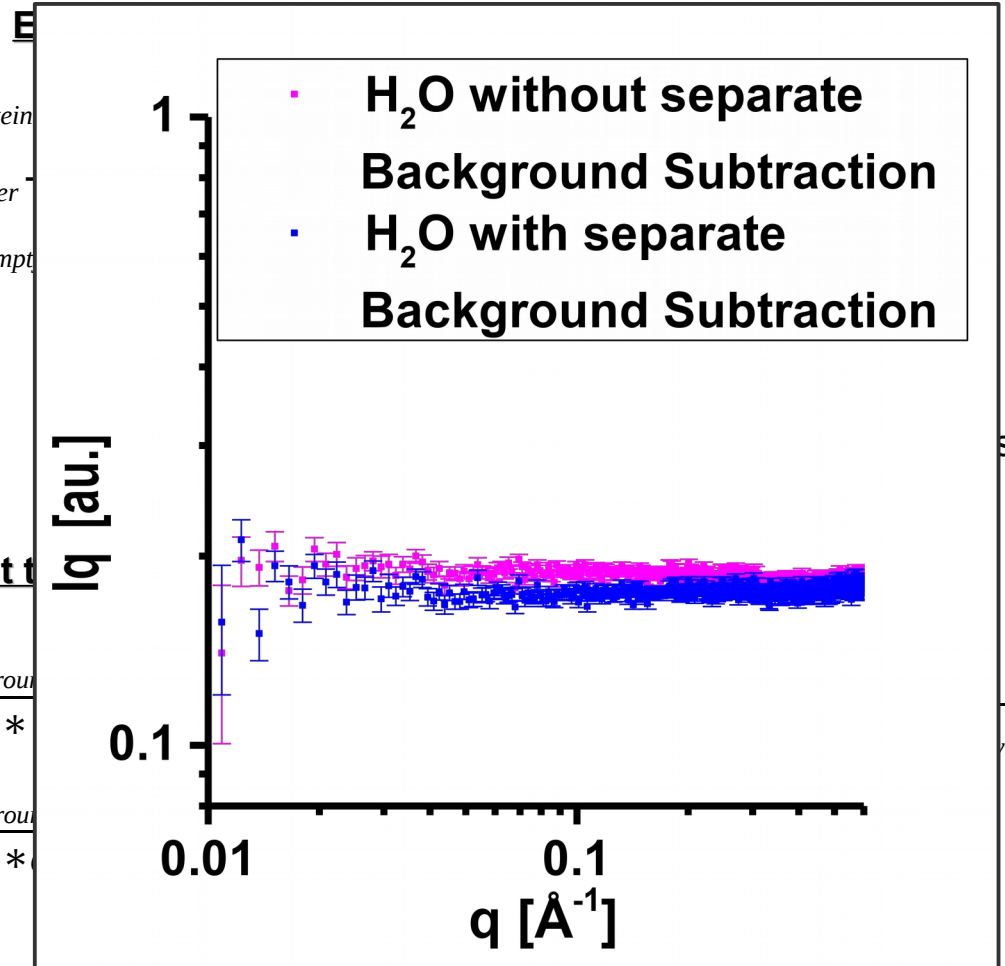

sition)

Subtracted scattering curve of IgG

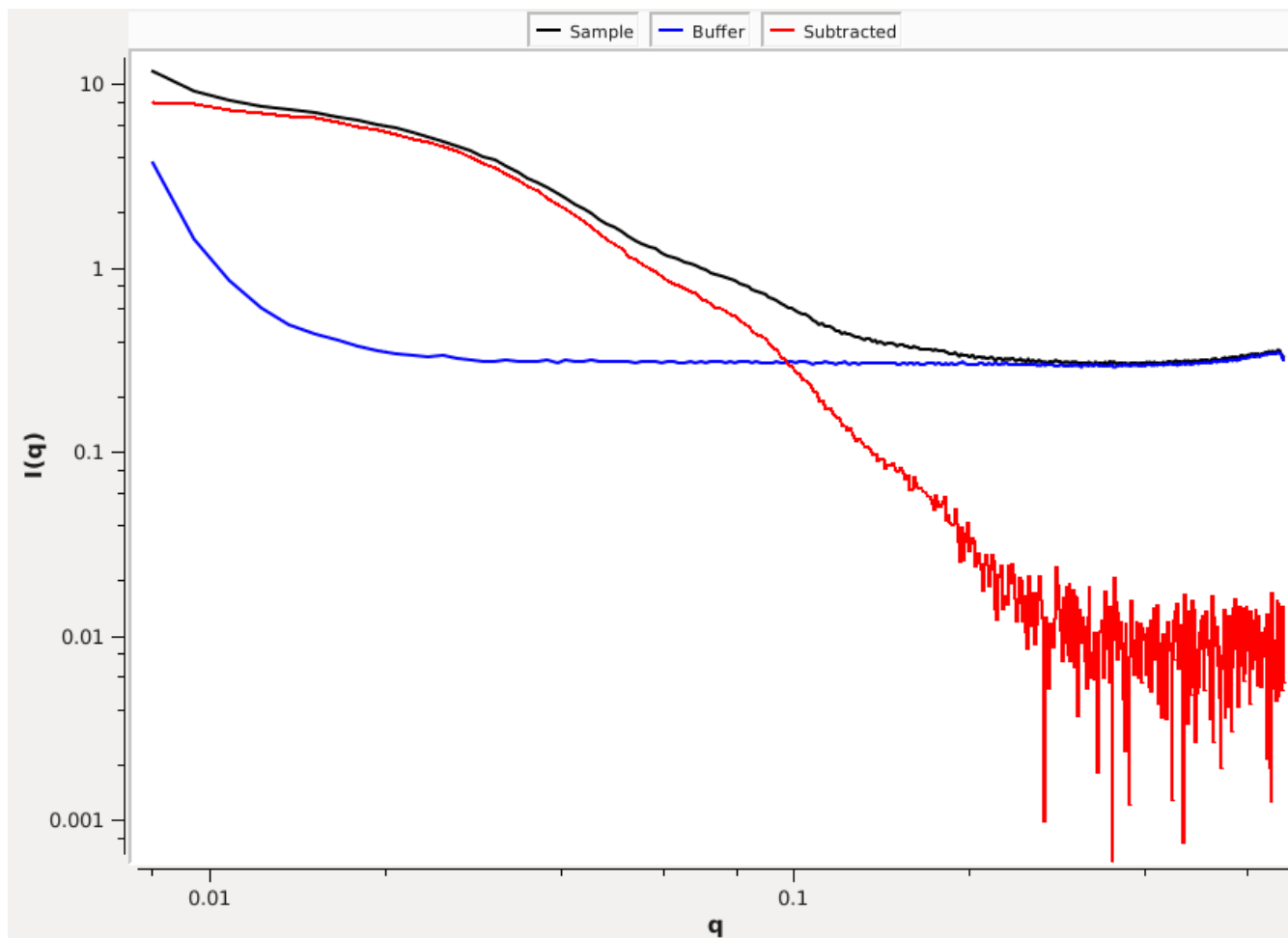

IgG 5 mg/ml 1h raw (black), subtracted (red), Buffer 2h (blue)

Subtracted scattering curve of IgG

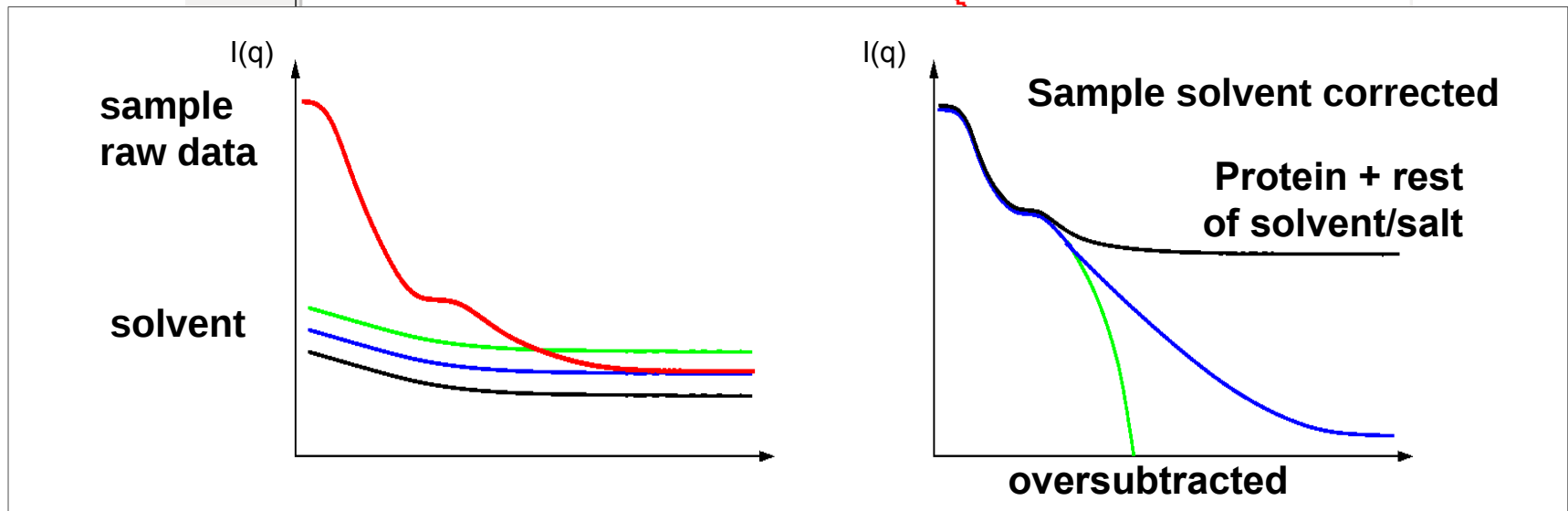
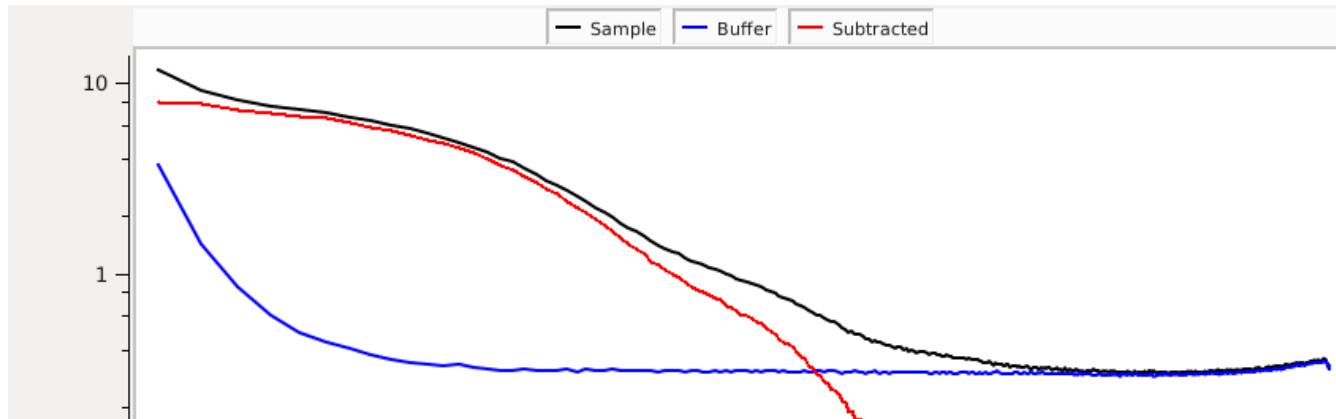

IgG 5 mg/ml 1h raw (black), subtracted (red), Buffer 2h (blue)

Scattering curves divided by concentration

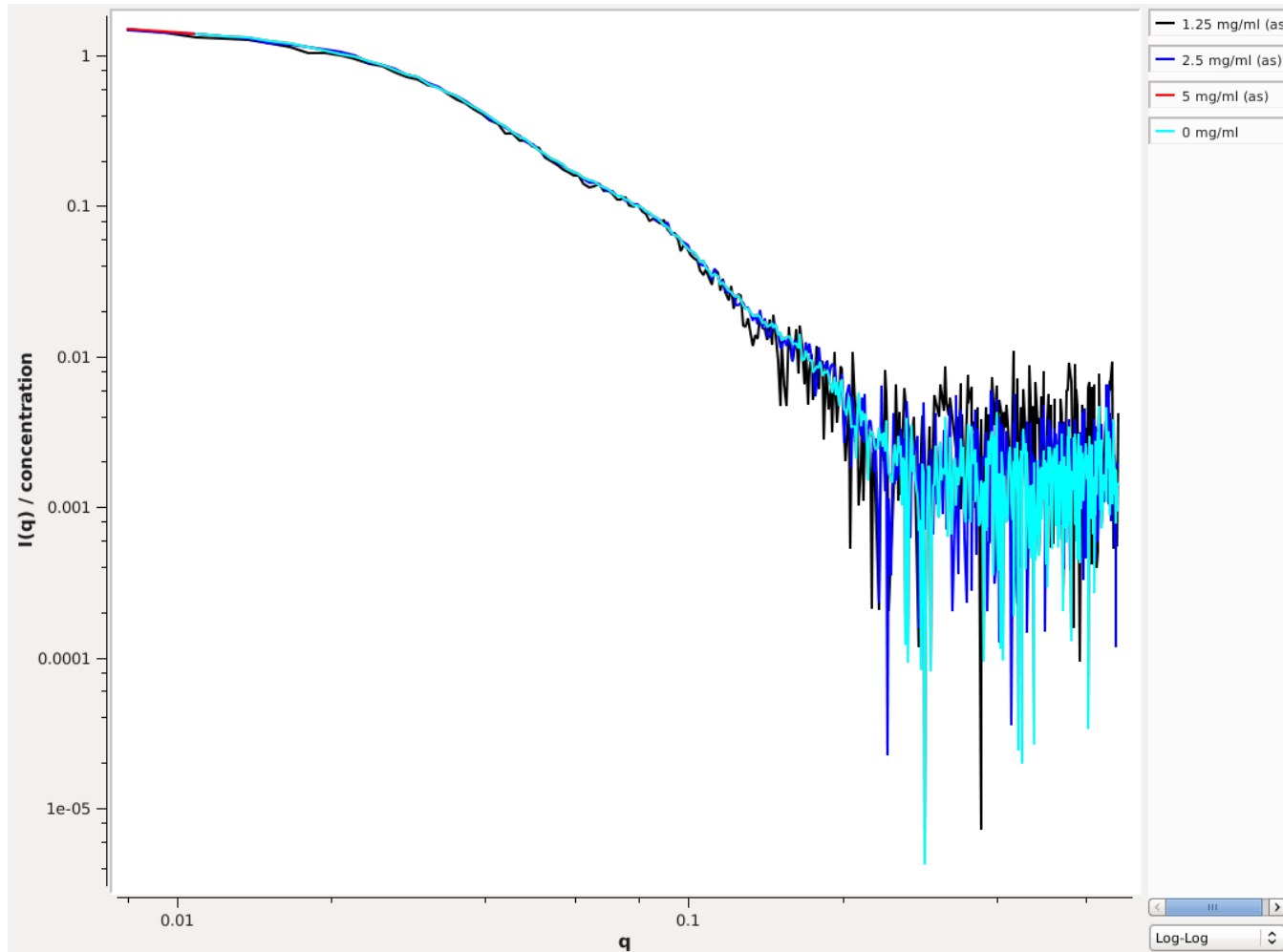

IgG curves are falling upon each other, no concentration dependent oligomerisation...

Sample preparation

What are we looking at?

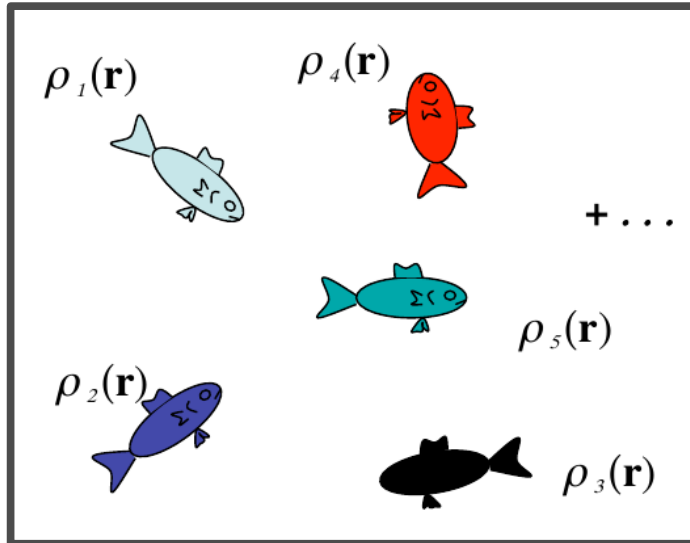

$$I(\mathbf{Q}) = |\mathbf{F}_1(\mathbf{Q})|^2 + |\mathbf{F}_2(\mathbf{Q})|^2 + \dots$$

Dirty sample

What are we looking at?

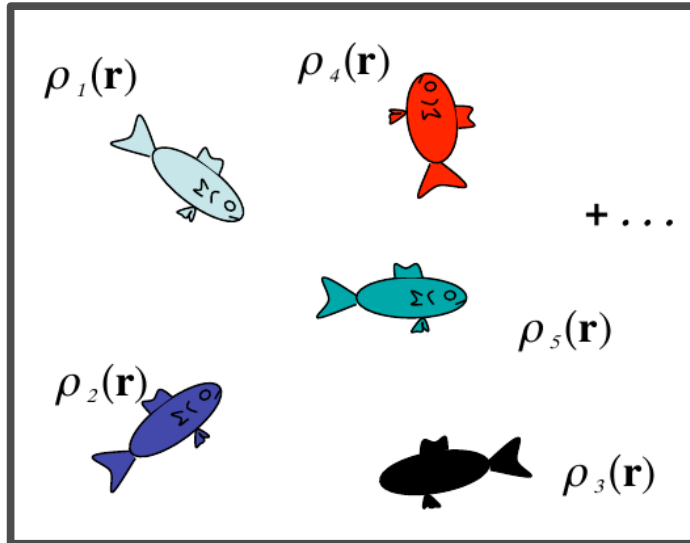

$$I(\mathbf{Q}) = |\mathbf{F}_1(\mathbf{Q})|^2 + |\mathbf{F}_2(\mathbf{Q})|^2 + \dots$$

Dirty sample

What do we get?

A statistical average of the scattering of all species in the illuminated volume

What are we looking at?

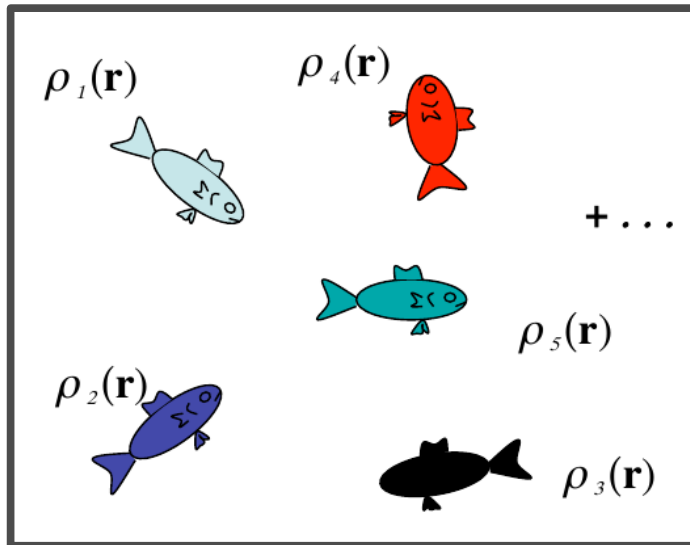

$$I(\mathbf{Q}) = |\mathbf{F}_1(\mathbf{Q})|^2 + |\mathbf{F}_2(\mathbf{Q})|^2 + \dots$$

Dirty sample

What do we get?

A statistical average of the scattering of all species in the illuminated volume

What do we get out of this?

A statistically averaged model of all species in the illuminated volume

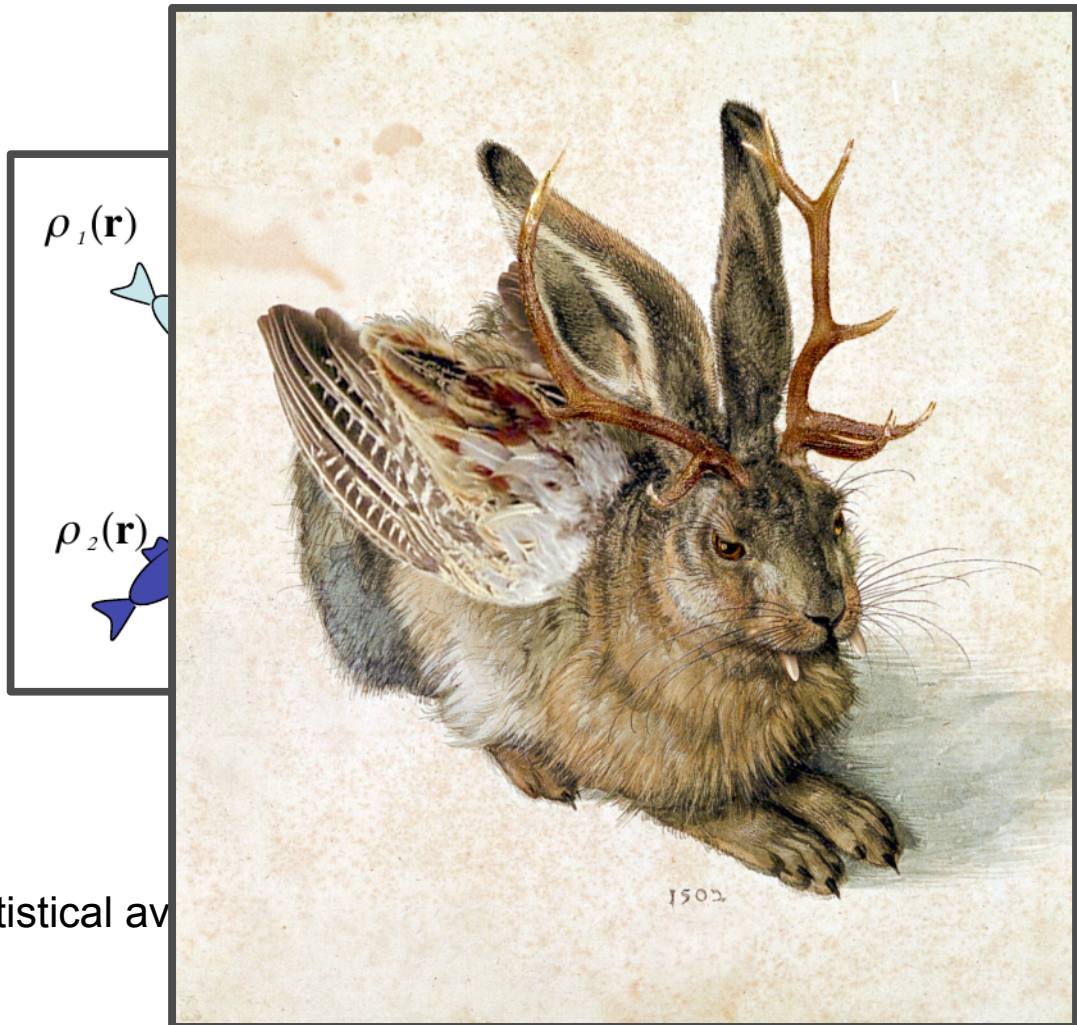

A statistical av

$$+ |\mathbf{E}_2(\mathbf{Q})|^2 + \dots$$

Dirty sample

inated volume

What do we get out of this?

A statistically averaged model of all species in the illuminated volume

What are we looking at?

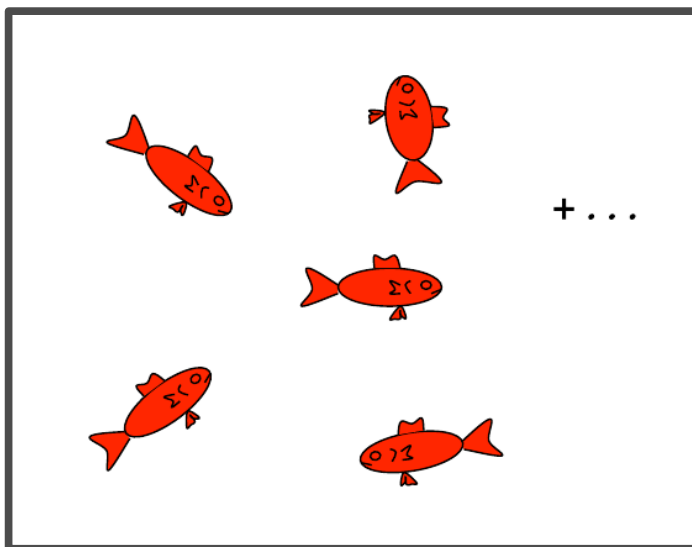

$$I(Q) = N \langle |F(Q)|^2 \rangle$$

Clean sample

What are we looking at?

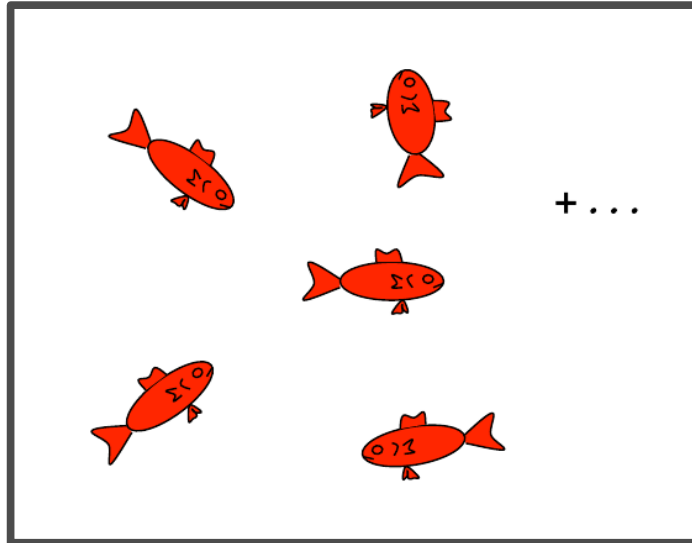

$$I(\mathbf{Q}) = N \langle |\mathbf{F}(\mathbf{Q})|^2 \rangle$$

Clean sample

What do we get?

A scattering profile of all particles in the illuminated volume

What are we looking at?

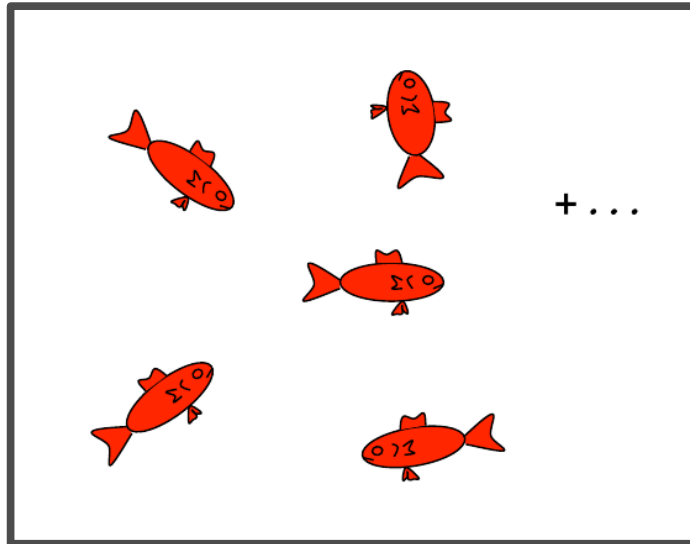

$$I(\mathbf{Q}) = N \langle |\mathbf{F}(\mathbf{Q})|^2 \rangle$$

Clean sample

What do we get?

A scattering profile of all particles in the illuminated volume

What do we get out of this?

An averaged model of all conformations of the protein in the illuminated volume

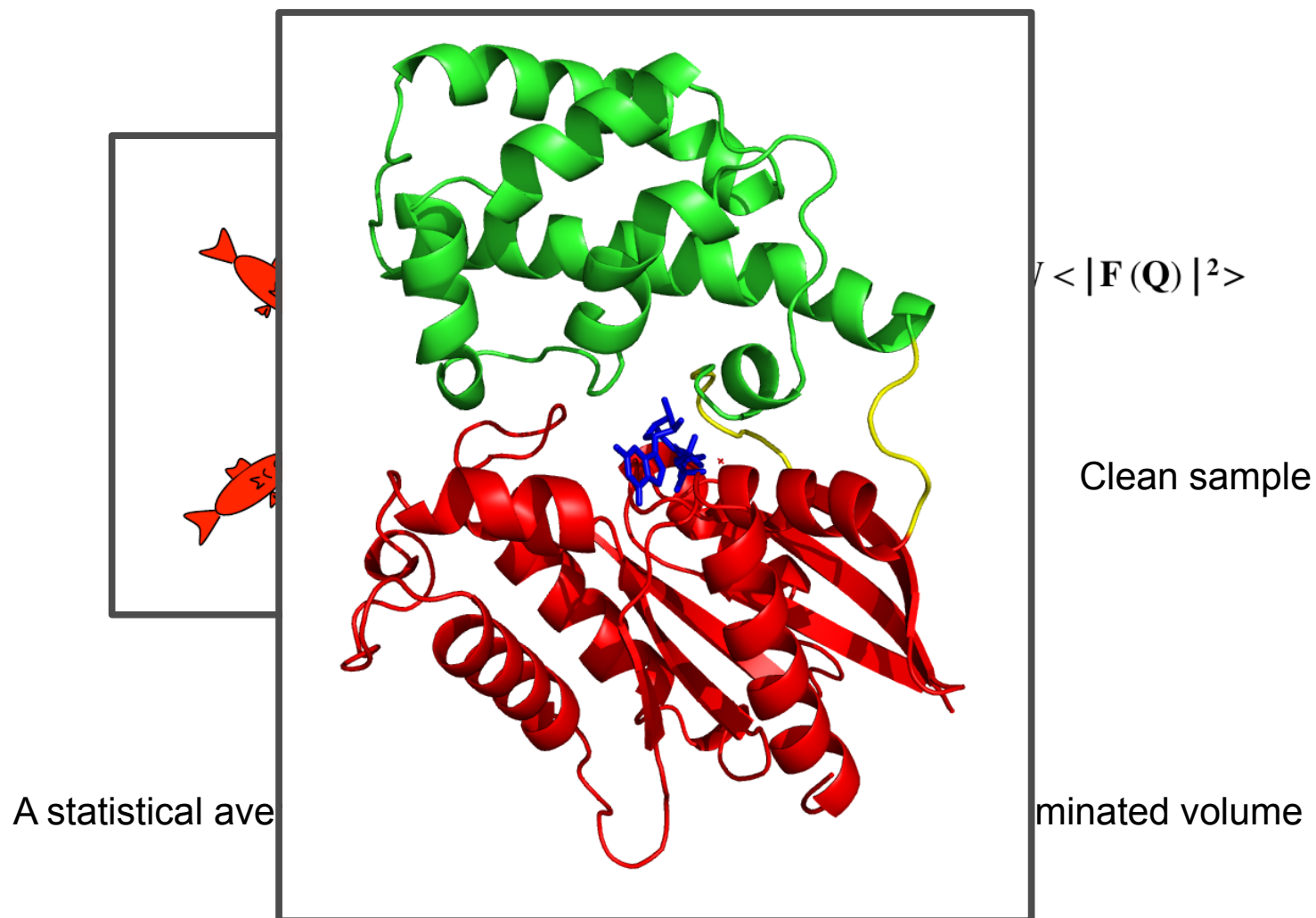

What do we get out of this?

An averaged model of all conformations of the protein in the illuminated volume

Characterisation of samples

SDS gel	unfolded AS-chain, no Agglomerates visible	NO
DLS	nativ conditions, sensitive to impurities and Agglomerates	OK
SLS	nativ conditions, sensitive to Agglomerates	OK
GPC - (SLS)	nativ conditions, semiquantitative analysis of impurities, Agglomerates	OK

Characterisation of samples

SDS gel	unfolded AS-chain, no Agglomerates visible	NO
DLS	nativ conditions, sensitive to impurities and Agglomerates	OK
SLS	nativ conditions, sensitive to Agglomerates	OK
GPC - (SLS)	nativ conditions, semiquantitative analysis of impurities, Agglomerates	OK

Agglomerates

$$V_{Part} \approx r^3, \quad I_{Part} = V_{Part}^2 P(q)$$



$$I_{Part} \propto r^6$$

Example

Stock solutions

- (1) Protein 10mg/ml,
100mM NaCl, 10mM Tris
- (2) RNA 100mg/ml, H₂O

Samples

Protein	(1) 70 μ l
RNA	(2) 7 μ l, 63 μ l H ₂ O
Complex	(1) 63 μ l, (2) 7 μ l
Buffer	
Water	

Stock solutions

- (1) Protein 10mg/ml,
100mM NaCl, 10mM Tris
- (2) RNA 100mg/ml, H₂O

Samples

Protein	(1) 70 μ l
RNA	(2) 7 μ l, 63 μ l H ₂ O
Complex	(1) 63 μ l, (2) 7 μ l
Buffer	
Water	

Example

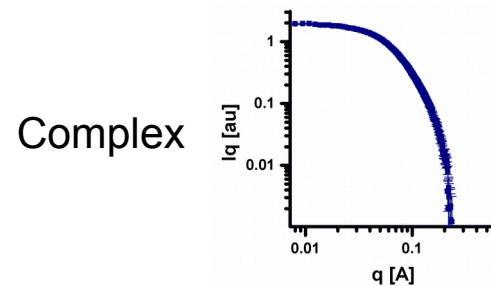
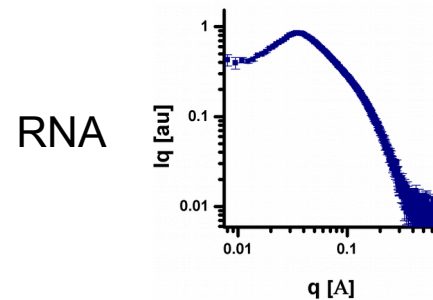
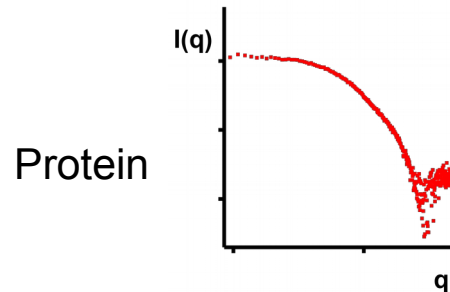

Stock solutions

- (1) Protein 10mg/ml,
100mM NaCl, 10mM Tris
- (2) RNA 100mg/ml, H₂O

Samples

- | | |
|---------|--|
| Protein | (1) 70 μ l |
| RNA | (2) 7 μ l, 63 μ l H ₂ O |
| Complex | (1) 63 μ l, (2) 7 μ l |
| Buffer | |
| Water | |

Example

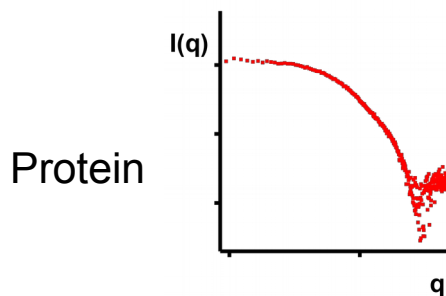

OK

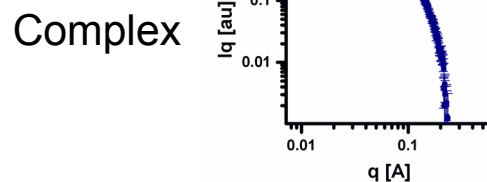
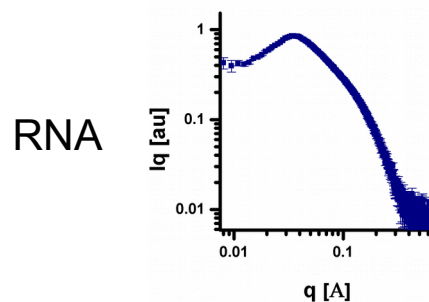

Stock solutions

- (1) Protein 10mg/ml,
100mM NaCl, 10mM Tris
- (2) RNA 100mg/ml, H₂O

Samples

- | | |
|---------|--|
| Protein | (1) 70 μ l |
| RNA | (2) 7 μ l, 63 μ l H ₂ O |
| Complex | (1) 63 μ l, (2) 7 μ l |
| Buffer | |
| Water | |

Example

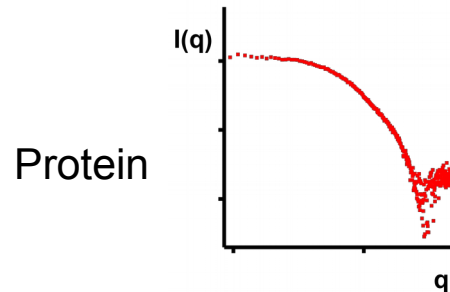

OK

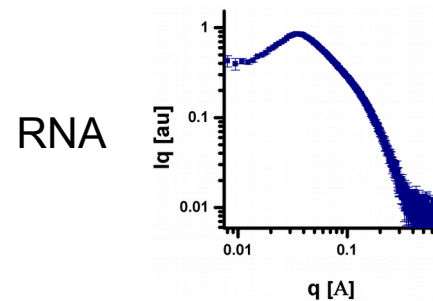

Structure factor due to polyionic repulsion

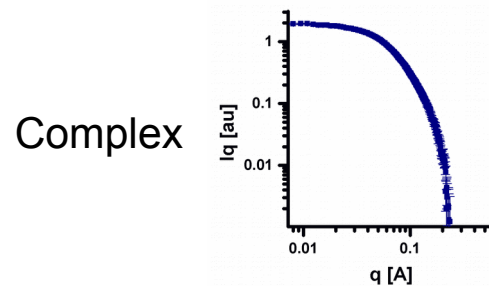

Stock solutions

- (1) Protein 10mg/ml,
100mM NaCl, 10mM Tris
- (2) RNA 100mg/ml, H₂O

Samples

- | | |
|---------|--|
| Protein | (1) 70 μ l |
| RNA | (2) 7 μ l, 63 μ l H ₂ O |
| Complex | (1) 63 μ l, (2) 7 μ l |
| Buffer | |
| Water | |

Example

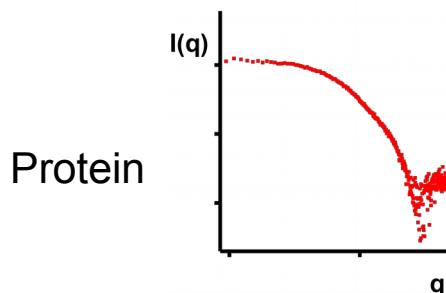

OK

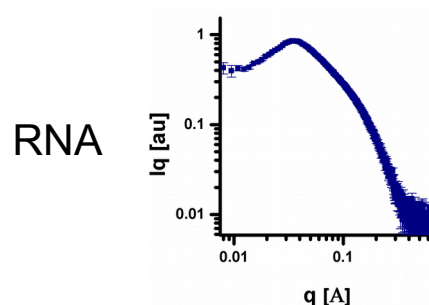

Structure factor due to polyionic repulsion

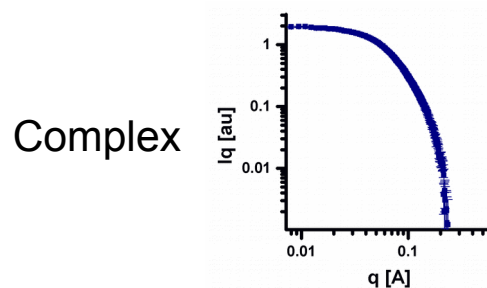

Oversubtraction sample and buffer do not have the same salt concentration

Stock solutions

- (1) Protein 10mg/ml,
100mM NaCl, 10mM Tris
- (2) RNA 100mg/ml, H₂O

Samples

- | | |
|---------|--|
| Protein | (1) 70 μ l |
| RNA | (2) 7 μ l, 63 μ l H ₂ O |
| Complex | (1) 63 μ l, (2) 7 μ l |
| Buffer | |
| Water | |

Example

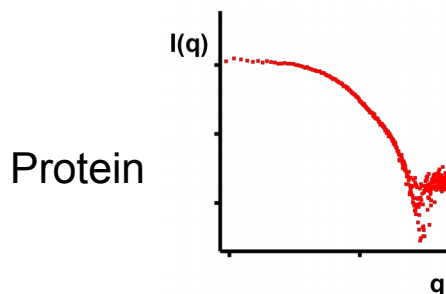

OK

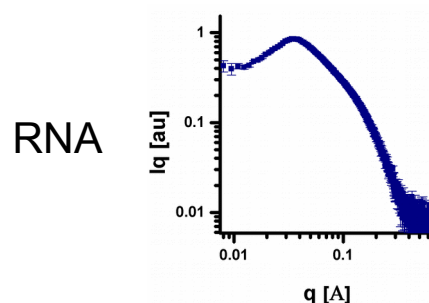

Structure factor due to polyionic repulsion

The repulsing electric field of polyions has to be screened out with 20 – 50 mM salt.

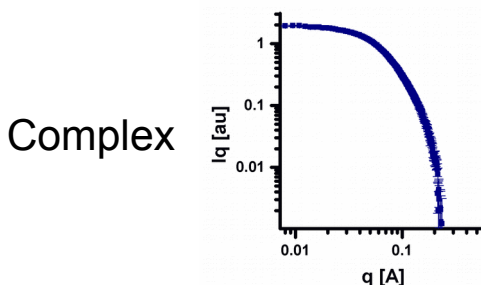

Oversubtraction sample and buffer do not have the same salt concentration

Stock solutions

- (1) Protein 10mg/ml,
100mM NaCl, 10mM Tris
- (2) RNA 100mg/ml, H₂O

Samples

- | | |
|---------|--|
| Protein | (1) 70 μ l |
| RNA | (2) 7 μ l, 63 μ l H ₂ O |
| Complex | (1) 63 μ l, (2) 7 μ l |
| Buffer | |
| Water | |

Example

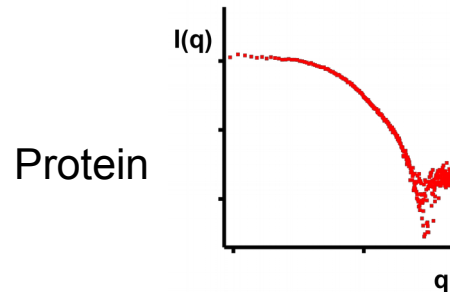

OK

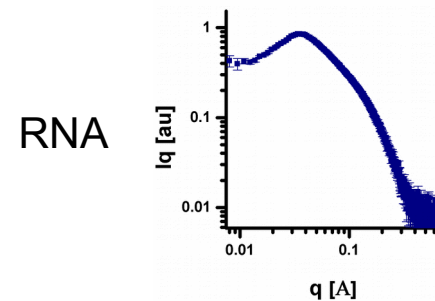

Structure factor due to polyionic repulsion

The repulsing electric field of polyions has to be screened out with 20 – 50 mM salt.

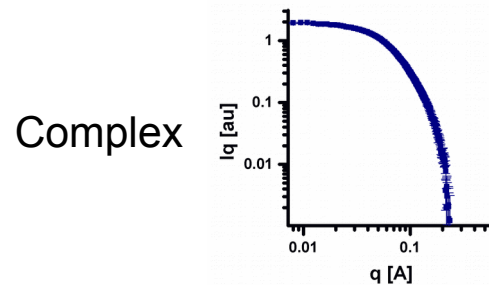

Oversubtraction sample and buffer do not have the same salt concentration

Preparation of both components in the same buffer or buffer exchange after mixing

Thank You

